

# Micas M2-W6940-64OC Switch

## Hardware Installation and Reference Guide

## **Copyright**

Copyright © 2024 Micas Networks Inc.

Micas Networks reserves all copyrights of this document.

Any reproduction, excerption, backup, modification, transmission, translation, or commercial use of this document or any portion of this document, in any form or by any means, without the prior written consent of Micas Networks is prohibited.

All other trademarks or registered trademarks mentioned in this document belong to their respective owners.

## **Disclaimer**

The purchased products, services, and features are stipulated by the contract made between Micas Networks and the customers. All or part of the products, services, and features described in this document may not be within the purchase scope or the usage scope. Unless otherwise specified in the contract, all statements, information, and recommendations in this document are provided "AS IS" without warranties, guarantees, or representations of any kind, either express or implied.

The information in this document is subject to change without notice. Micas Networks reserves the rights to change the content without any notice or warning.

This document is used only for reference. Micas Networks endeavors to ensure that the content in this document is accurate and reliable, but cannot ensure that no error or omission exists. All information in this document does not constitute any expressed or implied warranty.

## **Micas**

Website: <https://www.micasnetworks.com/>

Customer service email: [support@micasnetworks.com](mailto:support@micasnetworks.com)

# Preface

## Intended Audience

This document is intended for:

- Network engineers
- Technical support and servicing engineers
- Network administrators

## Technical Support

Official Website: <https://www.micasnetworks.com/support/>

## Signs

The signs used in this document are described as follows:

---

 **Danger**  
An alert that contains important safety instructions. Before you work on any equipment, be aware of the hazards involved and be familiar with standard practices for preventing accidents.

---

 **Warning**  
An alert that calls attention to important rules and information that if not understood or followed can result in data loss or equipment damage.

---

 **Caution**  
An alert that calls attention to essential information that if not understood or followed can result in function failure or performance degradation.

---

 **Note**  
An alert that contains additional or supplementary information that if not understood or followed will not lead to serious consequences.

---

 **Specification**  
An alert that contains a description of product or version support.

---

## Note

- The port type involved in this manual may be different from the actual situation. Please proceed with configuration according to the port type supported by the product.
- The display information involved in this manual may contain the content of other products (such as model and description). Please refer to the actual display

information.

- The routers and router product icons involved in this manual represent common routers and Layer 3 switches capable of routing protocols.

# Contents

<b>Preface .....</b>	<b>1</b>
----------------------	----------

<b>1 Overview.....</b>	<b>1</b>
------------------------	----------

1.1 About the M2-W6940-640C .....	1
1.2 Component Modules .....	1
1.3 Chassis.....	1
1.3.1 Appearance.....	2
1.3.2 LEDs.....	4
1.3.3 Ports.....	6
1.3.4 Cooling .....	7
1.3.5 Technical Specifications.....	7
1.3.6 Asset Tag .....	10
1.4 Power Module.....	11
1.4.1 PA3000I-F.....	12
1.5 Fan Module.....	14
1.5.1 FAN80-02-F .....	14
1.6 Cables.....	15
1.6.1 Ethernet Cable .....	15
1.6.2 Power Cord.....	16
1.6.3 Grounding Wire.....	17

<b>2 Preparing for Installation.....</b>	<b>18</b>
--	-----------

2.1 Safety Guidelines.....	18
2.1.1 General Precautions.....	18
2.1.2 Chassis-Lifting Guidelines .....	18
2.1.3 Electricity Safety .....	19
2.1.4 Preventing ESD Damage .....	19
2.1.5 Laser Safety.....	19
2.1.6 Storage Guidelines.....	20
2.2 Site Requirements.....	20
2.2.1 Floor Loading.....	20
2.2.2 Airflow .....	20
2.2.3 Space.....	20
2.2.4 Temperature .....	20

2.2.5 Humidity .....	21
2.2.6 Cleanliness .....	21
2.2.7 System Grounding .....	22
2.2.8 Preventing Electromagnetic Interference .....	23
2.2.9 Surge Protection .....	23
2.3 Rack-Mounting Guidelines .....	23
2.4 Tools .....	24
2.5 Unpacking the Switch .....	25
2.5.1 Verifying the Shipped Content .....	25
2.5.2 Unpacking the Container .....	25
<b>3 Installing the Switch .....</b>	<b>28</b>
3.1 Installation Procedure .....	28
3.2 Installing the Rack .....	29
3.2.1 Installation Guidelines .....	29
3.2.2 Procedure .....	29
3.3 Installing the Chassis .....	30
3.3.1 Installation Guidelines .....	30
3.3.2 Mounting the Brackets .....	30
3.3.3 Mounting the Chassis on the Rack .....	31
3.4 Installing the Protective Grounding Wire .....	32
3.4.1 Installation Guidelines .....	32
3.4.2 Procedure .....	32
3.5 Installing and Removing the Fan Module .....	32
3.5.1 Installing the Fan Module .....	32
3.5.2 Removing the Fan Module .....	33
3.6 Installing and Removing the Power Module .....	34
3.6.1 Installing the Power Module .....	34
3.6.2 Removing the Power Module .....	34
3.7 Installing the Optical Transceiver .....	35
3.8 Verifying Installation .....	35
3.9 Connecting the Power Cord .....	36
<b>4 Commissioning .....</b>	<b>37</b>
4.1 Setting Up the Configuration Environment .....	37
4.2 Powering on the Device .....	38
4.2.1 Checklist Before Power-on .....	38
4.2.2 Power-on .....	39

4.2.3 Checklist Before Power-on.....	39
<b>5 Monitoring and Maintenance .....</b>	<b>40</b>
5.1 Monitoring.....	40
5.1.1 Monitoring the LEDs.....	40
5.1.2 Running the CLI Commands.....	40
5.2 Maintenance.....	40
5.2.1 Replacing the Power Module.....	40
5.2.2 Replacing the Fan Module.....	41
5.2.3 Replacing the Lithium Battery.....	41
5.2.4 Replacing the Fuse.....	41
<b>6 Troubleshooting .....</b>	<b>43</b>
6.1 Flowchart.....	43
6.2 Common Issues .....	44
6.2.1 Forgetting Login Password.....	44
6.2.2 AC Power Module Failure .....	44
6.2.3 Fan Module Not Rotating .....	44
6.2.4 No Output on the Console .....	44
6.2.5 Garbled Output on the Console.....	44
6.2.6 Optical Port Linkdown.....	45
<b>7 Appendix .....</b>	<b>46</b>
7.1 Labeling Process.....	46
7.1.1 Hand Writing on Labels.....	46
7.1.2 Pasting Labels.....	46
7.1.3 Label Contents.....	47
7.2 Connectors and Media.....	47
7.2.1 100BASE-TX/10BASE-T Port .....	47
7.2.2 1000BASE-T Port .....	48
7.3 Surge Protection.....	50
7.3.1 Installing an AC Power Arrester .....	50
7.3.2 Installing an Ethernet Port Arrester .....	51
7.4 Site Selection .....	52
7.5 Recommended Cabling .....	52





# 1 Overview

## 1.1 About the M2-W6940-64OC

The M2-W6940-64OC switch is a next-generation 800GE core switch featuring high-performance, high-density, and low-latency launched by Micas Networks for Artificial Intelligence (AI) and other applications. The M2-W6940-64OC switch delivers Top of Rack (ToR) uplink aggregation and diverse data center features. It can be used with the M2-W6500 series switches for a high-performance and high-reliability data center network.

**Table 1-1 M2-W6940-64OC Overview**

Chassis	800GE OSFP Ports	25GE SFP28 Ports	Expansion Module Slots	Power Redundancy	Fan Redundancy
M2-W6940-64OC	64	2	N/A	1 + 1(210 V AC to 240 V AC)	3 + 1

### **Note**

- The product images involved in this manual are for indicative purpose only. The appearance is subject to the actual equipment.
- The equipment is equipped with two power modules and four fan modules by default. The power and fan redundancy design ensures uninterrupted service upon replacement of modules.

## 1.2 Component Modules

The M2-W6940-64OC adopts the modular design. Compliant with industry standards, the design differentiates modules and integrates module interfaces to ensure an integrated system with independent function modules.

**Table 1-2 Component Modules**

Chassis	Product ID	Airflow Direction	Power Module	Fan Module
M2-W6940-64OC	M2-W6940-64OC-FA	Front-to-rear airflow	PA3000I-F	FAN80-02-F

## 1.3 Chassis

The M2-W6940-64OC hardware system consists of a chassis, a power supply system, and a cooling system.

- Power supply system: provides two power module slots and supports 1 + 1 power

redundancy (210 V AC to 240 V AC).

- Cooling system: provides four fan module slots and supports 3 + 1 fan redundancy.

**Note**

The management software is already pre-installed in the system.

### 1.3.1 Appearance

#### 1. Appearance

**Figure 1-1 Front View of the M2-W6940-640C**

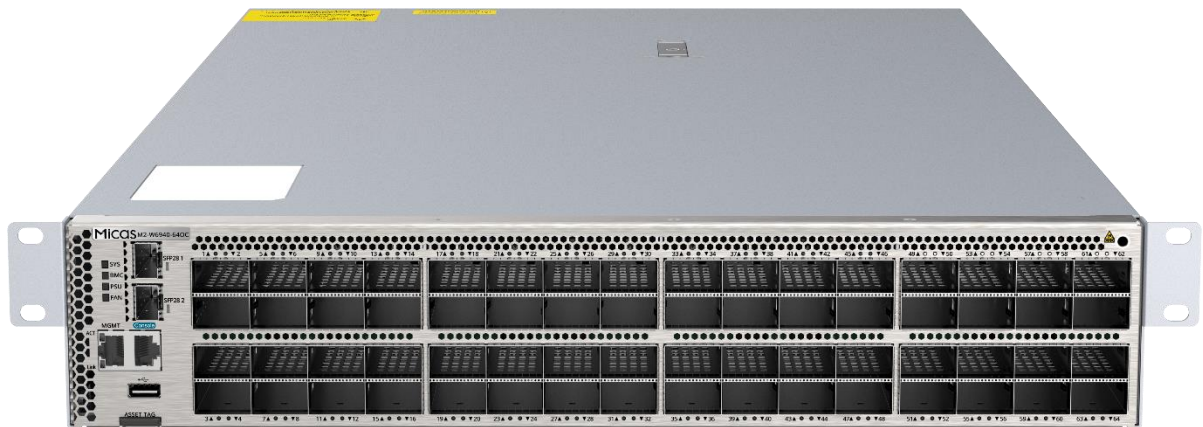
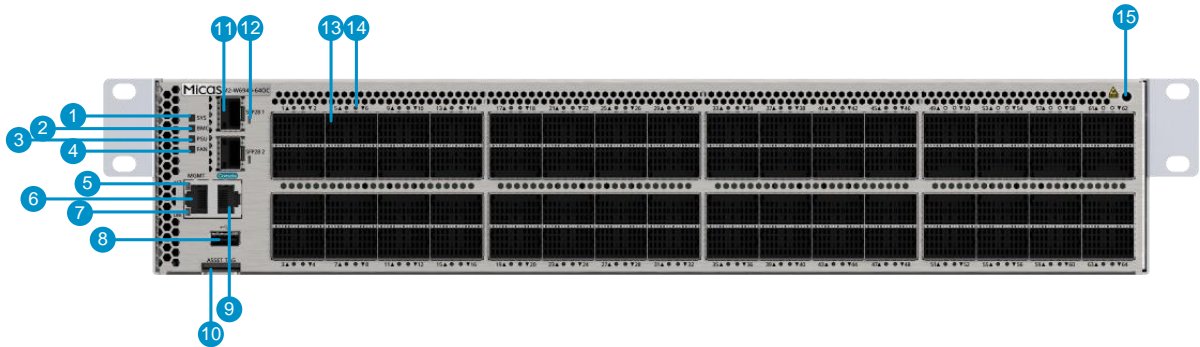

**Figure 1-2 Rear View of the M2-W6940-640C**



## 2. Structure

**Figure 1-3 Front Panel Structure**



**Table 1-3 Front Panel Components**

No.	Component
1	System status LED
2	BMC status LED
3	Power status LED
4	Fan status LED
5	Management port ACT status LED
6	Management port
7	Management port LINK status LED
8	USB port
9	Console port
10	Asset tag
11	SFP28 port
12	SFP28 port LED
13	OSFP port
14	OSFP port LED
15	Ground for static-preventive wrist strap

**Figure 1-4 Rear Panel Structure**



**Table 1-4 Rear Panel Components**

No.	Component
1	Fan module slot
2	Ground for ESD-preventive wrist strap
3	Grounding stud
4	Power module slot

### 1.3.2 LEDs

**Table 1-5 LEDs**

Silkscreen Label	LED	Description
SYS	Status LED	<ul style="list-style-type: none"> <li>● Solid green: The system is operating normally.</li> <li>● Blinking green: The system is starting up.</li> <li>● Solid yellow: The system generates a warning alarm about temperature.</li> <li>● Solid red: The system generates a critical alarm about temperature.</li> <li>● Off: The system is not receiving power or not operating even after receiving power.</li> </ul>
BMC	BMC status LED	<ul style="list-style-type: none"> <li>● Solid green: The BMC module is operating normally.</li> <li>● Blinking green: The BMC module is starting up.</li> <li>● Solid red: The BMC module is not functioning properly.</li> <li>● Off: The BMC module is not connected or not functioning properly after being connected.</li> </ul>
FAN	Fan status LED	<ul style="list-style-type: none"> <li>● Solid green: The fan modules are operating normally.</li> <li>● Blinking green: The fan modules are starting up.</li> </ul>

Silkscreen Label	LED	Description
		<ul style="list-style-type: none"> <li>● Solid yellow: A fan module is not installed or not functioning properly.</li> <li>● Solid red: Two or more fan modules are not functioning properly.</li> <li>● Off: The fan modules are not receiving power or not operating even after receiving power.</li> </ul>
PSU	Power status LED	<ul style="list-style-type: none"> <li>● Solid green: The power modules are operating normally.</li> <li>● Blinking green: The power modules are starting up.</li> <li>● Solid red: Two power modules are not installed or not functioning properly.</li> <li>● Solid yellow: A power module is not installed or not functioning properly.</li> <li>● Off: The power modules are not receiving power or not operating even after receiving power.</li> </ul>
1 to 64	OSFP port LED	<ul style="list-style-type: none"> <li>● Solid green: The port has made a successful 100/200/400/800 Gbps link.</li> <li>● Blinking green: The port is sending and receiving traffic at 100/200/400/800 Gbps.</li> <li>● Off: No link is detected for the port.</li> </ul>
SFP28 1 to 2	SFP28 port LED	<ul style="list-style-type: none"> <li>● Solid green: The port has made a successful 10/25 Gbps link.</li> <li>● Blinking green: The port is sending and receiving traffic at 10/25 Gbps.</li> <li>● Off: No link is detected for the port.</li> </ul>
LINK/ACT	Management port LED	<ul style="list-style-type: none"> <li>● LINK solid green: The port has made a successful 1000 Mbps link.</li> <li>● LINK solid yellow: The port has made a successful 10/100 Mbps link.</li> <li>● LINK off: No link is detected for the port.</li> <li>● ACT blinking green: The port is sending and receiving traffic at 10/100/1000 Mbps.</li> <li>● ACT off: The port is not sending or receiving traffic.</li> </ul>

### 1.3.3 Ports

**Table 1-6 Ports**

Port	Connector Type	Description	Accessory
800GE OSFP port	Subject to the optical transceiver	The 800GE OSFP port for uplink data transmission <ul style="list-style-type: none"> <li>● Optical attributes: Subject to the transceiver or optics</li> </ul>	800GE optical transceiver AOC
SFP28 port	Subject to the optical transceiver	The 25GE SFP28 port can be used as a management port for setting up the local or remote configuration environment. <ul style="list-style-type: none"> <li>● Optical attributes: Subject to the transceiver or optics</li> </ul>	25GE optical transceiver AOC DAC
Management port	RJ45	The management port is used to set up the local or remote configuration environment. <ul style="list-style-type: none"> <li>● Standards compliance: IEEE802.3ab</li> <li>● Working mode: 10/100/1000 Mbps with auto-negotiation and full-duplex</li> </ul>	CAT5 or higher cable
USB port	USB	The USB port is connected with a USB flash drive for configuration backup and firmware upgrade. <ul style="list-style-type: none"> <li>● USB 2.0</li> <li>● FAT32 file format</li> </ul>	USB 2.0 flash drive
Console port	RJ45	The console port is connected to a console for local configuration. <ul style="list-style-type: none"> <li>● Standards compliance: RS-232</li> <li>● Working mode: Duplex Universal Asynchronous Receiver/Transmitter (UART)</li> <li>● Baud rate:</li> </ul>	Console cable

Port	Connector Type	Description	Accessory
		<ul style="list-style-type: none"> <li>o Range: 9,600 bits/s to 115,200 bits/s</li> <li>o Default value: 115,200 bits/s</li> </ul>	

### 1.3.4 Cooling

The M2-W6940-640C adopts the front-to-rear airflow. Air flows in through the ports and out through the power module, as shown in [Figure 1-5](#).

**⚠ Caution**

- Maintain a minimum clearance of 200 mm (7.87 in.) around the equipment for air circulation.
- Dust the equipment every three months to avoid blocking the ventilation openings on the housing.

**Figure 1-5 Front-to-Rear Airflow**

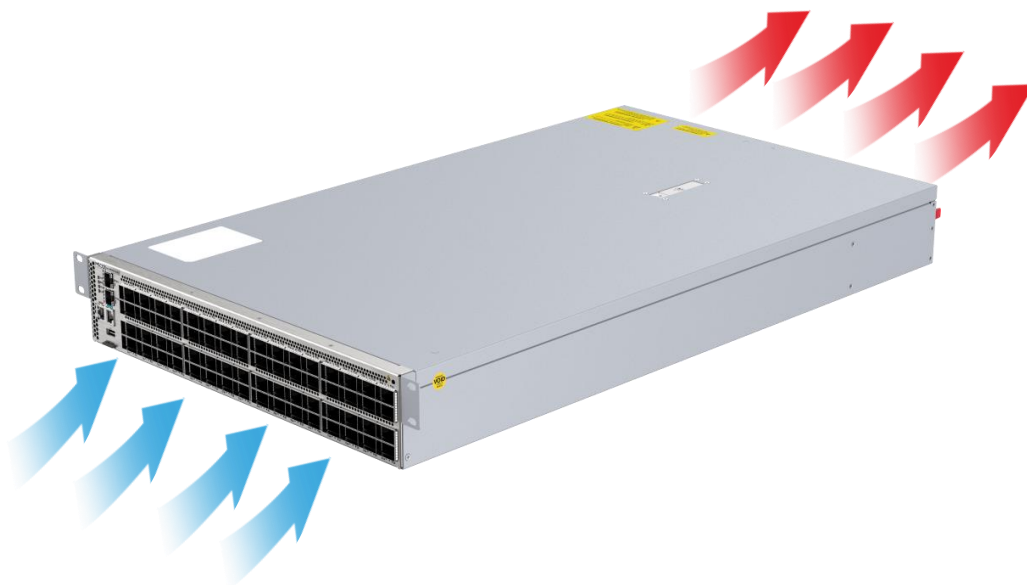

### 1.3.5 Technical Specifications

**Table 1-7 Technical Specifications**

Class	Item	Specification
Technical indicators	CPU	2.0 GHz eight-core
	Memory	DDR4 32GB
	Hard drive	240 GB

Class	Item	Specification
Physical characteristics	Dimensions (W x D x H)	<ul style="list-style-type: none"> <li>Without packing materials: 760 mm x 440 mm x 86.1 mm (29.92 in. x 17.32 in. x 3.39 in., 2 RU)</li> <li>With packing materials: 980 mm x 590 mm x 275 mm (38.58 in. x 23.23 in. x 10.83 in.)</li> </ul>
	Weight	<ul style="list-style-type: none"> <li>Full system (including four fan modules and two power modules) without packing materials: 23 kg (50.71 lbs)</li> <li>Full system (including four fan modules and two power modules) with packing materials: 31.8 kg (70.15 lbs)</li> </ul>
	Structure	Integrated chassis without expansion module slots <ul style="list-style-type: none"> <li>Two power module slots</li> <li>Four fan module slots</li> </ul>
Ports	Service port	64 x 800GE OSFP ports
	Console port	1 x RJ-45 serial console
	USB port	1 x UBS 2.0 port
	Management port	1 x Gigabit RJ45 port supporting backward compatibility
	SFP28 port	2 x 25GE SFP28 ports. An SFP28 port can be used as a management port.
Environment	Altitude	<ul style="list-style-type: none"> <li>Operating altitude: Below 3,800 m (12,467.74 ft.)</li> <li>Storage altitude: Below 5,000 m (16,404.20 ft.)</li> </ul>
	Temperature	<ul style="list-style-type: none"> <li>Operating temperature: 0°C to 40°C (32°F to 104°F) at an altitude below 1,800 m (5,905.51 ft.)</li> </ul> <hr/> <p><b>Note</b> At an altitude in the range of 1,800–5,000 m (5,905.51–16,404.20 ft.), every time the altitude increases by 220 m</p>



Class	Item	Specification
		<p>(721.78 ft.), the maximum temperature decreases by 1°C (1.8°F).</p> <hr/> <ul style="list-style-type: none"> <li>● Storage temperature: -40°C to +70°C (-40°F to +158°F)</li> </ul>
	Humidity	<ul style="list-style-type: none"> <li>● Operating humidity: 5% RH to 95% RH (non-condensing)</li> <li>● Storage humidity: 0% RH to 90% RH (non-condensing)</li> </ul>
	Noise	Sound pressure level at 27°C (80.6°F): < 78 dB
	Surge protection	<p>AC power protection</p> <ul style="list-style-type: none"> <li>● Common mode: 2 kV</li> <li>● Differential mode: 1 kV</li> </ul>
Power supply	Power supply mode	AC
	Power connector	Three-pin connector, subject to the power module
	Power consumption	<ul style="list-style-type: none"> <li>● Max: 2,980 W</li> <li>● Typical: 1,450 W</li> <li>● Static: 750 W</li> </ul>
	Voltage	<p>AC:</p> <ul style="list-style-type: none"> <li>● 100 V AC to 120 V AC, 50 Hz/ 60 Hz, not supporting 1 + 1 redundancy</li> <li>● 200 V AC to 240 V AC, 50 Hz / 60 Hz, supporting 1 + 1 redundancy</li> </ul>
	AC input	<ul style="list-style-type: none"> <li>● Rated voltage: 100 V AC to 120 V AC/200 V AC to 240 V AC</li> <li>● Frequency: 50 Hz/60 Hz</li> <li>● Max. voltage range: 90 V AC to 264 V AC (47 Hz to 63 Hz)</li> <li>● Max. rated current: 16 A</li> </ul>
	Max. output power consumption	3,000 W
	Airflow direction	Front-to-rear airflow (air exhaust on power module panel)

Class	Item	Specification
Cooling	Cooling mode	Drawing air
	Fan type	Swappable fan
Reliability	Mean Time Between Failures (MTBF)	25.12 years
	Mean Time to Recovery (MTTR)	0.5 hours
	Availability	0.9999977
	Power redundancy	1 + 1 (210 V AC to 240 V AC)
	Fan redundancy	3 + 1
	Hot swapping	Hot swappable power and fan modules
Certification and regulation compliance	Regulation compliance	Safety regulation
		EMC standard
		RoHS and environment protection regulation

**! Warning**

- Operation of this equipment in a residential environment could cause radio interference.
- This equipment is not suitable for use in locations where children are likely to be present.
- This equipment should be installed in the equipment room. Only a skilled person should be allowed to install, replace, or service this equipment. Do not open the enclosure when the equipment is running. Cut off the power supply before opening the enclosure in case of an electric shock.

### 1.3.6 Asset Tag

The asset tag is in the lower left corner of the front panel. The tag can be pulled out of the panel. You can add your own asset tracking label without interfering with the intended air flow.

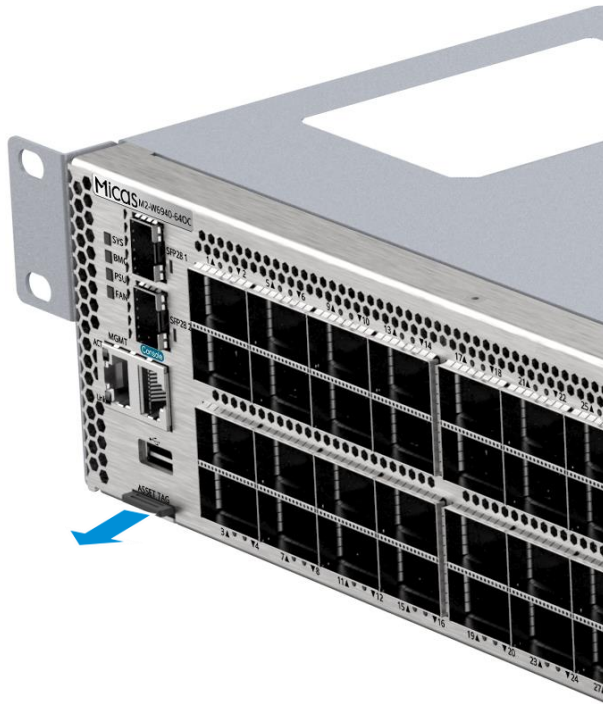
**Figure 1-6 Asset Tag**

## 1.4 Power Module

The smart power module for the M2-W6940-64OC supports power consumption management and hot swapping. It can obtain the output power, output current, and operating temperature in real time.

---

### **⚠ Caution**

- To improve system stability and availability, you are advised to configure 1 + 1 power redundancy (210 V AC to 240 V AC). The chassis configured with power redundancy works in current-sharing mode.
  - If any slot is unoccupied, install a blank filler plate to enable proper airflow and to keep dust out of the chassis.
  - Unplug the power cord before installing or removing the power module.
-

## 1.4.1 PA3000I-F

### 1. Appearance

Figure 1-7 Structure

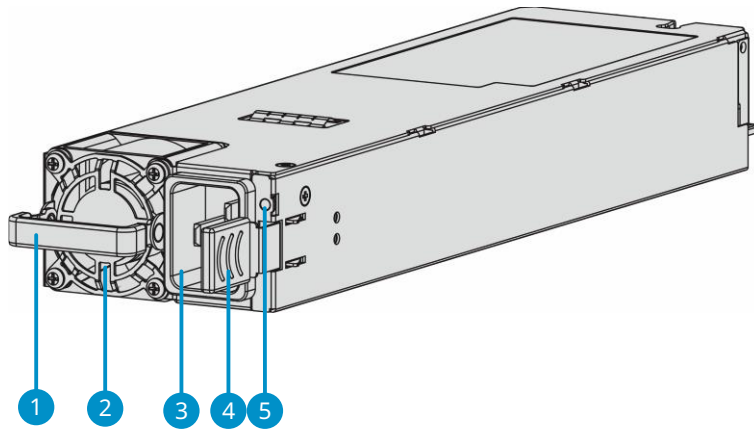

Table 1-8 Components

No.	Component	Description
1	Handle	Handle of the power module
2	Fan	Forward fan
3	Power connector	Three-pin connector
4	Latch LED	Latch of the power module
5	LED	Power status LED

### 2. LED

Table 1-9 LED

Silkscreen Label	LED	Description
N/A	Power status LED	<ul style="list-style-type: none"> <li>● Solid green: The power module is outputting power normally.</li> <li>● Blinking green at 1 Hz:               <ul style="list-style-type: none"> <li>○ The power module is in PS OFF state with only 12 V standby output.</li> <li>○ The power module is in the cold standby status and not outputting power.</li> </ul> </li> <li>● Solid red:               <ul style="list-style-type: none"> <li>○ The power module is not functioning properly</li> </ul> </li> </ul>

		<p>(overcurrent, overvoltage, or fan failure).</p> <ul style="list-style-type: none"> <li>○ The power module in redundancy mode is removed.</li> <li>● Blinking red at 1 Hz: The power module is operating but with alarms, such as high power, high current, high temperature, and low fan rotation speed.</li> <li>● Off: The power module is not receiving power or not operating even after receiving power.</li> </ul>
--	--	---

### 3. Technical Specifications

**Table 1-10 Technical Specifications**

Item	Specification
Dimensions (W x D x H)	Without packing materials: 268.4 mm x 73.5 mm x 40 mm (10.59 in. x 2.89 in. x 1.57 in.)
Weight	Without packing materials: 1.3 kg (2.87 lbs)
Power connector	C20 connector for connection with AC power cord
Rated input voltage	110 V AC (not supporting power redundancy)/220 V AC, 50 Hz/60 Hz
Max. input voltage	100 V AC to 240 V AC, 50 Hz to 60 Hz
Rated input current	16 A
Rated output current	<ul style="list-style-type: none"> <li>● 99 A (90 V AC to 140 V AC)</li> <li>● 214 A (180 V AC to 200 V AC)</li> <li>● 230 A (200 V AC to 208 V AC)</li> <li>● 246 A (208 V AC to 264 V AC)</li> </ul>
Rated output voltage	12 V DC
Rated output power consumption	<ul style="list-style-type: none"> <li>● 1,200 W (90 V AC to 140 V AC)</li> <li>● 2,600 W (180 V AC to 200 V AC)</li> <li>● 2,800 W (200 V AC to 208 V AC)</li> <li>● 3,000 W (208 V AC to 264 V AC)</li> </ul>
Hot swapping	Supported
Cooling	Front-to-rear airflow (air exhaust on power module panel)
Overvoltage protection	Supported
Overcurrent protection	Supported
Over-temperature	Supported

Item	Specification
protection	

## 1.5 Fan Module

### 1.5.1 FAN80-02-F

#### 1. Appearance

Figure 1-8 Structure

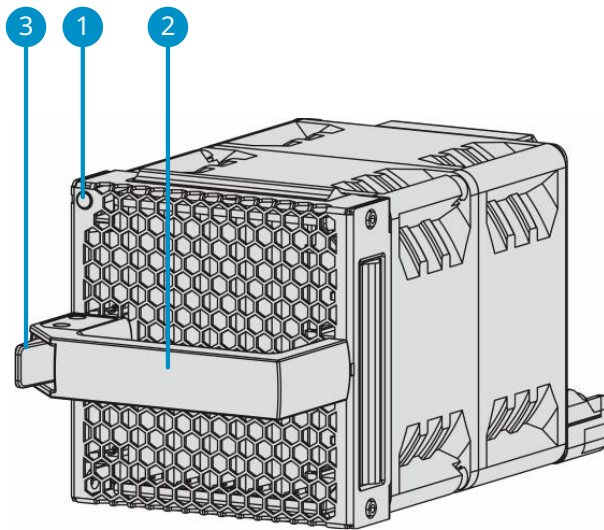

Table 1-11 Components

No.	Component	Description
1	LED	Fan status LED
2	Handle	Handle of the fan module
3	Latch	Latch of the fan module

#### 2. LED

Table 1-12 LED

Silkscreen Label	LED	Description
Status	Fan status LED	<ul style="list-style-type: none"> <li>● Solid green: The fan module is operating normally.</li> <li>● Blinking green: The fan module is being initialized.</li> <li>● Solid red: The fan module is not functioning properly.</li> </ul>

Silkscreen Label	LED	Description
		<ul style="list-style-type: none"> <li>Off: The fan module is not receiving power.</li> </ul>

### 3. Technical Specifications

**Table 1-13 Technical Specifications**

Item	Specification
Dimensions (W x D x H)	Without packing materials: 80 mm x 175 mm x 80 mm (3.15 in. x 6.89 in. x 3.15 in.)
Weight	Without packing materials: 0.8 kg (1.76 lbs)
Number of fans	1
Rated voltage	12 V DC
Max. power consumption	168 W
Typical power consumption	126 W
Max. fan rotation speed	18,000 RPM
Max. airflow volume	183.83 CFM
Max. air pressure	34,429.07 Pa
Hot swapping	Supported
Cooling	Front-to-rear airflow (air exhaust on fan module panel)
Automatic speed regulation	Supported
Status monitoring	Rotation speed monitoring and fault alarm

## 1.6 Cables

### 1.6.1 Ethernet Cable

- 1000BASE-T: 100-ohm CAT5e Unshielded Twisted Pair (UTP) or Shielded Twisted Pair (STP) cables with a transmission distance of up to 100 meters (328.08 ft.).
- 100BASE-TX: 100-ohm CAT5 or CAT5e UTP or STP cables with a transmission distance of up to 100 meters (328.08 ft.).
- 10BASE-T: 100-ohm CAT3, CAT4, CAT5, and CAT5e UTP or STP cables with a transmission distance of up to 100 meters (328.08 ft.).

**Note**

- For twisted pair connection and pin assignments, see [7.2 Connectors and Media](#).
- The equipment supports automatic MDI/MID-X crossover detection. Both straight through and crossover cables are applicable.

## 1.6.2 Power Cord

### 1. Applicable Power Cords

**Table 1-14 Power Cords**

Chassis	Product ID	AC Power Cord
M2-W6940-640C	M2-W6940-640C-FA	CAB-2M-IEC-16A-B(US)

**Caution**

- The power cords that come with the power modules comply with standards of the destination country or region.
- Select power cords according to power modules. Power cords applicable to power modules are subject to update without prior notification.

### 2. AC Power Cord

Select AC power cords based on the types of power sockets used in your equipment room. Micas provides the following types of power cords to suit different the power sockets:

- Power distribution unit (PDU) cords: C19 straight female to C20 straight male AC power cords, delivered with a PDU with C14 straight female connectors, as shown in [Figure 1-9](#).
- Country-specific power cords: delivered in compliance with standards of the destination country or region.

**Figure 1-9 AC Power Cord Structure**



### 1.6.3 Grounding Wire

Figure 1-10 Grounding Wire Structure

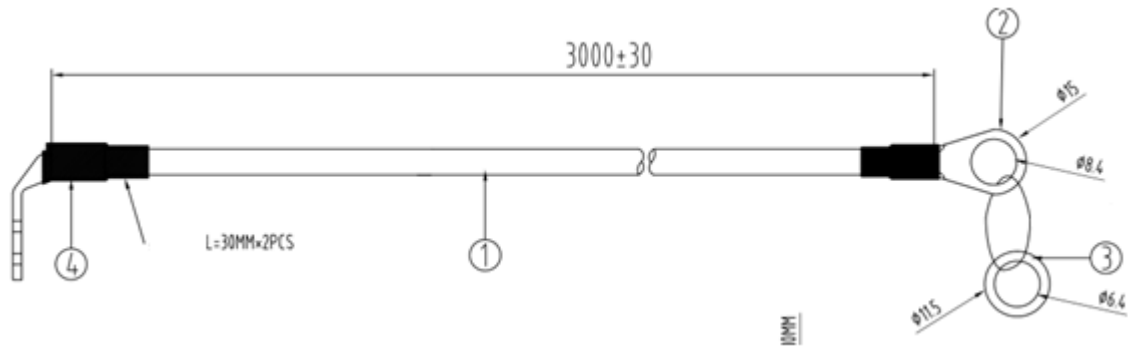

Table 1-15 Grounding Wire Components

No.	Component	Description
1	Cable sleeve	UL1015 12 AWG, yellow-green, 3 meters (9.84 ft.), crimping
2	Small lug	RNB 5.5-8 lug
3	Copper washer	ID: 6.4 mm (0.25 in.), OD: 11.5 mm (0.45 in.), T: 1 mm (0.04 in.)
4	Large lug	Two-hole lug

# 2 Preparing for Installation

## 2.1 Safety Guidelines

---

**Note**

- To avoid personal injury or equipment damage, review the safety guidelines in this chapter before you begin the installation.
  - The following safety precautions may not include all the potentially hazardous situations.
- 

### 2.1.1 General Precautions

- Install the equipment in a standard 19-inch EIA rack.
- Keep the chassis clear and dust free. Avoid liquid inside the equipment.
- Keep the equipment far away from heat sources.
- Ensure that the rack and power distribution system are properly grounded.
- Wear an ESD-preventive wrist strap and an ESD-preventive glove during installation and maintenance.
- Avoid disconnecting or connecting the power cord before powering off the switch.
- Keep the equipment away from walk areas.
- Do not wear loose clothing or ornament that may get caught in the chassis.
- Keep tools and components away from areas where you or others could trip over them.
- You are advised to use UPS for guaranteed power protection.
- Turn off all power supplies and unplug all power cords and cables before installing or removing the switch.
- This equipment is not suitable for use in locations where children are likely to be present.

### 2.1.2 Chassis-Lifting Guidelines

- The chassis is not intended to be moved frequently.
- When lifting the chassis, balance the weight of the chassis between your feet.
- To prevent personal injury or equipment damage, never attempt to lift or tilt the chassis using the handles of power or fan module.
- The equipment must be installed in access-restricted locations.
- Avoid transporting the bare equipment. Instead, transport the equipment with its packing materials.
- Do not create a stack containing a greater number of chassis than what is indicated on the packing carton during transportation. Avoid placing the chassis side up or upside down.
- Do not stack bare demo units. Separate demo units using foam blocks. Do not stack over three layers, each with a height of up to 1 meter (3.28 ft.). Lay the foam blocks side-by-side.

### 2.1.3 Electricity Safety

- Always observe the local regulations and standards. Only trained and qualified personnel should be allowed to operate the equipment.
- Carefully check your work area for possible hazards, such as ungrounded power extension cables, missing safety grounds, and moist floors.
- Locate the emergency power-off switch in the room. In the case of an electrical accident, you will be able to quickly turn off the power.
- Never assume that power is disconnected from a circuit. Instead, always check.
- Do not subject the equipment to dampness and avoid liquid inside the equipment.

#### **Danger**

- Improper electric operations may cause a fire, electric shock, and other accidents, which may lead to severe and fatal personal injury and equipment damage.
- Direct or indirect touch through a wet object with high-voltage and mains supply can bring a fatal danger.

### 2.1.4 Preventing ESD Damage

Static electricity comes from two major sources:

- Outdoor high-voltage power cords, lightning, and other external electric fields
- Indoor flooring materials and equipment enclosure

When the static electricity exceeds a certain value, it will damage the circuit and equipment. To prevent ESD damage, attention should be paid to the following items:

- Ensure that the chassis is connected to earth ground.
- The site should be as dust-free as possible.
- Maintain appropriate humidity levels.
- Wear an ESD-preventive wrist strap and an ESD-preventive glove, ensuring that they are properly grounded.
- Handle component boards by their handles or edges only. Do not touch the printed circuit boards or connectors.
- Place a removed component board in a static-shielding container.
- Avoid contact between the printed circuit boards and clothing. The ESD-preventive wrist strap and glove only protect components from ESD voltages on the body. ESD voltages on clothing can still cause damage.

### 2.1.5 Laser Safety

The optical transceivers are Class I laser products. Attention should be paid to the following items:

- When an optical transceiver is working, ensure that the port is connected to an optical cable or covered by a dust cap to keep out dust and prevent burning your eyes.
- Do not stare into any optical port.

** Danger**

Do not approach or stare into any optical port under any circumstances. This may cause permanent damage to your eyes.

## 2.1.6 Storage Guidelines

To ensure normal operation, plan for your installation site according to the temperature and humidity requirements.

** Caution**

If the equipment has been powered off for more than 18 months, power on the equipment and run it for consecutive 24 hours to activate the device.

## 2.2 Site Requirements

The equipment must be installed indoors for normal operation and prolonged service life. The following sections provide specific information to help you plan for a proper operating environment.

### 2.2.1 Floor Loading

Ensure that the floor under the rack supporting the chassis is capable of supporting the combined weight of the rack and all the other components.

### 2.2.2 Airflow

To ensure adequate airflow through the chassis, maintain a minimum clearance of 20 cm (7.87 in.) around air vents. Route the cables and power cords through the cable management brackets to avoid blocking air intake vents. Dust the equipment every three months to prevent blocking the ventilation openings on the housing.

### 2.2.3 Space

- You are advised to have a pathway of 0.8 meters (2.62 ft.) wide in the equipment room. This space ensures that you can remove the components and perform routing maintenance easily.
- The front and rear of the chassis must remain unobstructed to ensure adequate airflow and prevent overheating inside the chassis.

### 2.2.4 Temperature

To ensure normal operation and prolonged service life of the equipment, maintain an appropriate temperature in the equipment room. Otherwise, the equipment may be damaged.

- A high temperature can accelerate the aging process of insulation materials, greatly reducing the availability of the equipment and severely affecting its service life.

See [Table 1-7 Technical Specifications](#) for the temperature requirement.

** Note**

The operating temperature is measured at the point that is 1.5 m (4.92 ft.) above the floor and 0.4 m (1.31 ft.) before the equipment with no protective plates in front or at the back of the equipment.

## 2.2.5 Humidity

To ensure normal operation and prolonged service life of the equipment, maintain an appropriate humidity in the equipment room. Otherwise, the equipment may be damaged.

- In an environment with a high relative humidity, the insulating material is prone to poor insulation or even electricity leakage.
- In an environment with a low relative humidity, the insulating strip may dry and shrink, resulting in screw loosening. Furthermore, internal circuits are prone to static electricity.

See [Table 1-7 Technical Specifications](#) for the humidity requirement.

### **i** Note

The operating humidity is measured at the point that is 1.5 m (4.92 ft.) above the floor and 0.4 m (1.31 ft.) before the equipment with no protective plates in front or at the back of the equipment.

## 2.2.6 Cleanliness

The indoor dust takes on a positive or negative static electric charge when falling on the switch, causing poor contact of the metallic joint. Such electrostatic adhesion may occur more easily when the relative humidity is low, not only affecting the service life of the switch, but also causing communication faults. The following table lists the requirements for the dust and particles in the equipment room:

**Table 2-1 Dust and Particles Requirement**

Minimum Dust and Particles Diameter	Unit	Maximum Quantity
0.5 $\mu$ m	Particles/ $m^3$	$3.5 \times 10^5$
5 $\mu$ m	Particles/ $m^3$	$3.0 \times 10^3$

Apart from dust, there are also requirements on the salt, acid, and sulfide in the air of the equipment room. These harmful substances will accelerate metal corrosion and component aging. Therefore, the equipment room should be properly protected against harmful gases, such as sulfur dioxide and hydrogen sulfide. The following table lists limits on harmful gases.

**Table 2-2 Gas Requirement**

Gas	Average		Maximum ( $mg/m^3$ )	
	$mg/m^3$	$cm^3/m^3$	$mg/m^3$	$cm^3/m^3$
Sulfur dioxide ( $SO_2$ )	0.3	0.11	1.0	0.37

Gas	Average		Maximum (mg/m <sup>3</sup> )	
	mg/m <sup>3</sup>	cm <sup>3</sup> /m <sup>3</sup>	mg/m <sup>3</sup>	cm <sup>3</sup> /m <sup>3</sup>
Hydrogen sulfide (H <sub>2</sub> S)	0.1	0.071	0.5	0.36
Chlorine (Cl)	0.1	0.034	0.3	0.1
Nitric oxide (NO)	0.5	0.26	1.0	0.52

---

**Note**

The average value is measured over one week. The maximum value is the upper limit of the harmful gas measured in one week for up to 30 minutes every day.

---

## 2.2.7 System Grounding

A reliable grounding system is the basis for stable and reliable operation, which is indispensable for preventing lightning strikes and interference. Carefully check the grounding conditions at the installation site according to the grounding specifications, and complete grounding properly based on the site situation.

- Safety Grounding

Ensure that the rack and power distribution system are securely grounded. Otherwise, electric shocks may occur when the insulation resistance between the power module and the chassis becomes small.

---

**Caution**

The building should provide a protective ground connection to ensure that the equipment is connected to a protective earth.

---

- Lightning Grounding

The surge protection system is an independent system consisting of a lightning rod, a downlead conductor, and a connector connected to the grounding system. The grounding system is usually used for power reference grounding and safety grounding of the rack.

---

**Note**

See [7.3 Surge Protection](#) for details.

---

- EMC Grounding

Grounding for the EMC design includes shielded grounding, filter grounding, noise, interference suppression, and level reference.

The grounding resistance should be smaller than 1-ohm. Connect the grounding terminal to the ground before operating the equipment.

There are two grounding studs in the upper right corner of the rear panel. They are pasted with a conspicuous label.

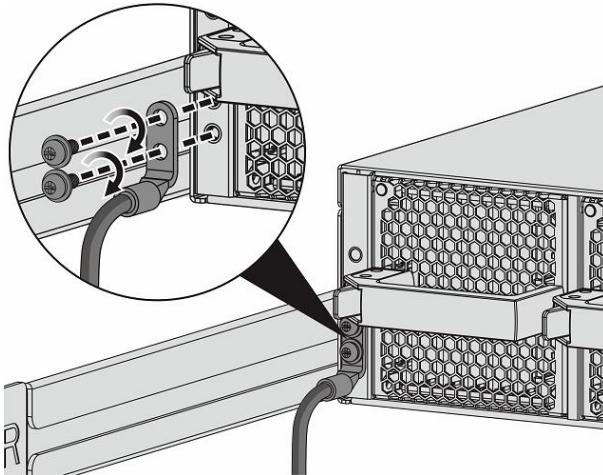
**Figure 2-1 Grounding Stud**

## 2.2.8 Preventing Electromagnetic Interference

Electromagnetic interference mainly comes from outside the equipment or application system and affects the equipment through capacitive coupling, inductive coupling, electromagnetic waves, and other conduction modes.

- Interference prevention measures should be taken for the power supply system.
- Keep the equipment far away from the grounding facility and surge protector facility of the power device.
- Keep the equipment far away from high-frequency current devices such as the high-power radio transmitting station and radar launcher.
- Take electromagnetic shielding measures when necessary.

## 2.2.9 Surge Protection

Although the equipment can guard against lightning strikes, strong lightning strikes may still damage the equipment. Take the following surge protection measures:

- Ensure that the grounding wire of the rack is in good close contact with the ground.
- Ensure that the neutral point of the AC power socket is in close contact with the ground.
- You are advised to install a power arrester in front of the power input end to enhance surge protection for the power supply.

## 2.3 Rack-Mounting Guidelines

If you plan to install the equipment on a rack, ensure that the rack meets the following requirements:

**Figure 2-2 19-Inch Rack**

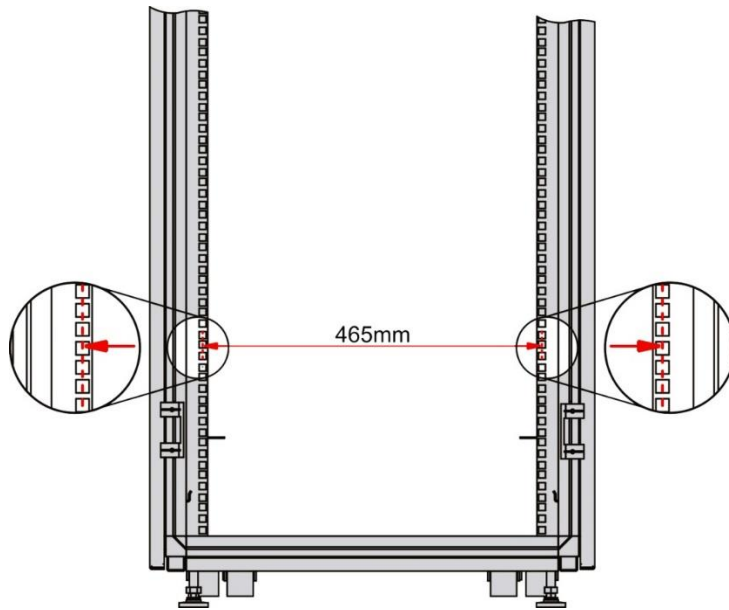

- (1) Use a four-post 19-inch EIA rack.
- (2) The left and right square hole rack posts are 465 mm (18.31 in.) apart.
- (3) The square hole rack post is at least 180 mm (7.09 in.) from the front door, and the front door is at most 25 mm (0.98 in.) thick. This ensures an available clearance of at least 155 mm (6.10 in.). The rack depth (distance between front and rear doors) is at least 1,000 mm (39.37 in.).
- (4) The guide rails or tray can bear the weight of the chassis and its components.
- (5) The rack has a reliable grounding terminal for the chassis to connect to earth ground.
- (6) The rack has a reliable heat dissipation system. The open area of front and rear doors is greater than 50%.

## 2.4 Tools

**Table 2-3 Tools**

Tools	Description
Common tools	Philips screwdriver, utility knife, adjustable wrench, ESD-preventive clothing
Dedicated tools	ESD-preventive wrist strap, ESD-preventive glove, marker, cage nuts, screws, cables, and cable ties

**Note**

The tool kit does not come with the equipment.



## 2.5 Unpacking the Switch

### 2.5.1 Verifying the Shipped Content

**Table 2-4 Default Shipping Container Components**

Kit	Description
Chassis kit	Chassis, yellow-green grounding wire, <i>Quick Start Guide</i> , <i>Package Contents</i> , and documentation
Module kit	Modules, <i>Package Contents</i> , and <i>Quick Start Guide</i>

**Note**

The preceding items are delivered against the purchase contract. Check your goods carefully against *Package Contents* or purchase contract. If you have any questions, contact your distributor.

### 2.5.2 Unpacking the Container

- (1) Cut off the packing straps on the shipping box with scissors, place the box on a flat surface, and check whether the seal on top of box is intact.

**Figure 2-3**

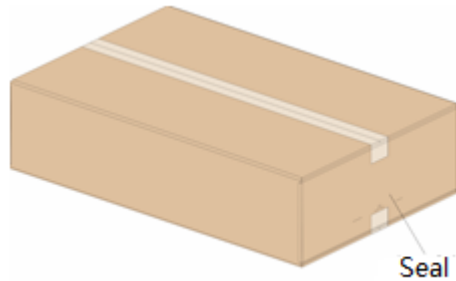

- (2) Use a paper cutter to cut the tapes holding the side flaps of the box, and open the shipping box.

**Figure 2-4**

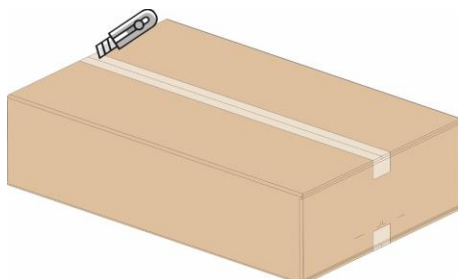

- (3) Take out the accessory box, verify that the main accessories are not missing, and then keep the accessory box handy.

**Figure 2-5**

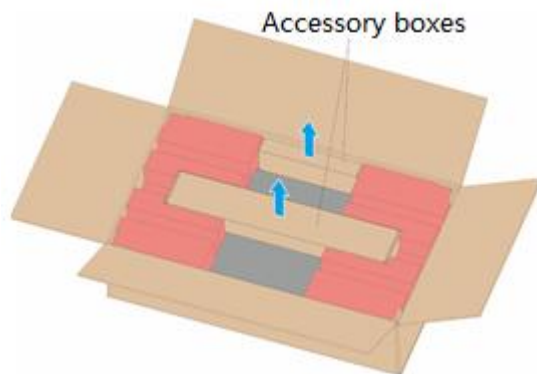

- (4) Place the switch with the panel foam facing upwards.
- (5) Remove the panel foam and set it aside.

**Figure 2-6**

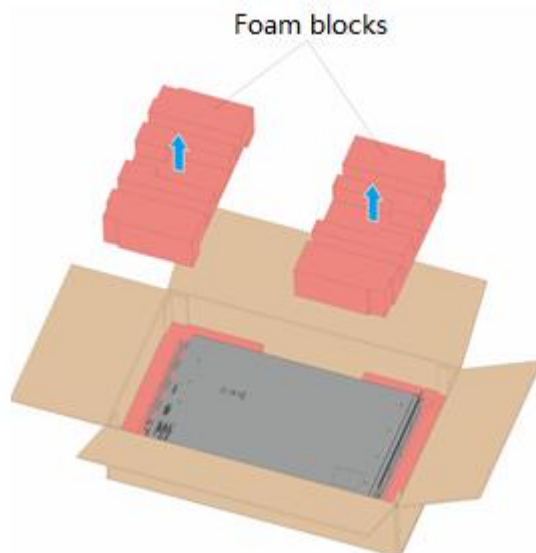

- (6) Move the switch with both hands onto the shipping box of another product, and remove the foam on the other side.

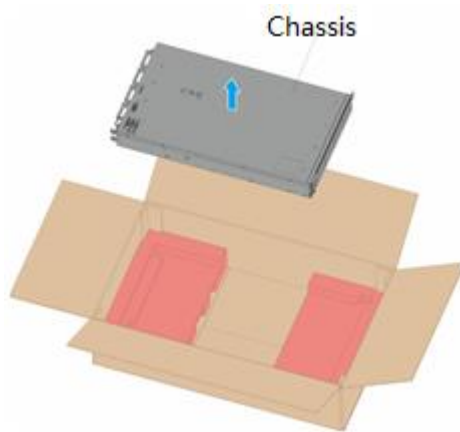
**Figure 2-7**

- (7) Remove the tape on the static-shielding container, open and reach into the bag with both hands, grab the two sides of the chassis, lift the switch out of the static-shielding container, and place it on an antistatic workbench.

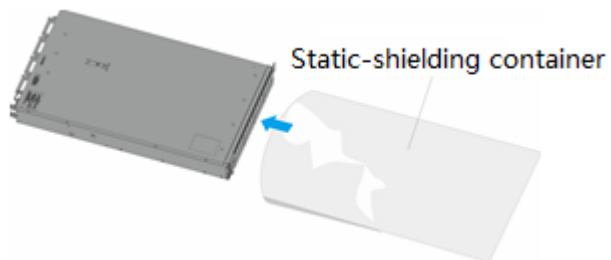
**Figure 2-8**

- (8) Press the power module inward to ensure that the power module is fully seated into the system.

# 3 Installing the Switch

Make sure that guidelines and requirements in chapter 2 have been met before you begin the installation. Plan for the installation site, networking mode, power supply, and cabling in advance.

## 3.1 Installation Procedure

Figure 3-1 Installation Procedure

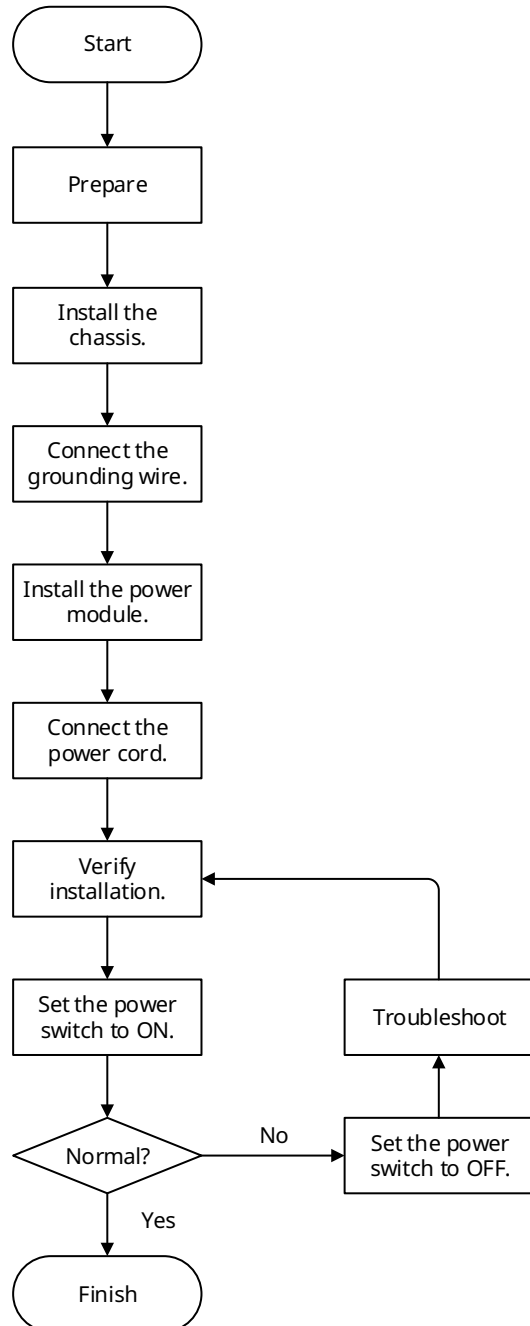

(1) [Installing the Rack](#)

- (2) [Installing the Chassis](#)
- (3) [Installing the Protective Grounding Wire](#)
  
- (4) [Installing and Removing the Fan Module](#)
- (5) [Installing and Removing the Power Module](#)
- (6) [Installing the Optical Transceiver](#)
- (7) [Verifying Installation](#)
- (8) [Connecting the Power Cord](#)

## 3.2 Installing the Rack

### 3.2.1 Installation Guidelines

Make sure the following guidelines are met:

- All expansion bolts for securing the rack base to the ground are installed from bottom to up in the sequence of large flat washer, spring washer, and nut, and the installation holes on the base are flush with the expansion bolts.
- The rack is stable and sturdy after installation has been completed.
- The rack is installed on the ground vertically.
- When multiple racks are placed side by side in the equipment room, they are parallel in a line with a deviation of up to 5 mm (0.20 in.).
- The front and rear doors of the rack can open and close properly after installation has been completed. Also verify that the cabinet locks are functioning and that there are a complete set of keys.
- All labeling on the rack and equipment is accurate.
- Blank filler plates are installed in the empty slots.
- All the screws and bolts that will be used to install the rack are of the same type.
- All modules installed in the equipment are secured and all captive screws are properly tightened.
- In order to prevent rodents and other small animals from entering the rack, the cabling exit openings at the top and bottom of the rack are fitted with rodent-resistant nets with seams of up to 15 mm (0.59 in.) in diameter.
- The rack always has a set of static-preventive wrist straps available.

---

#### Note

- See [7.4 Site Selection](#) for site selection guidelines.
  - See [7.5 Recommended Cabling](#) for cabling guidelines.
- 

### 3.2.2 Procedure

- (1) Make sure that there is enough space before installing the rack. Reserve enough clearance before the front and rear doors for equipment maintenance.
- (2) Mount and fasten the rack in the planned location.
- (3) Install the appropriate chute and cables.

- (4) Fit the appropriate accessories to the rack.

## 3.3 Installing the Chassis

### 3.3.1 Installation Guidelines

Please verify that the front and rear brackets of the rack are in the right locations before mounting. If the front brackets are too close to the front door, there will not be sufficient clearance between the front panel and the door. As a result, the front door cannot be closed after Ethernet cables and optical fibers are connected to the chassis. Generally, maintain a minimum clearance of 10 mm (0.39 in.) between the front panel and the front door. Before installation, verify the following guidelines are met:

- The rack has been secured.
- The various components in the rack have been installed.
- There are no obstacles inside or around the rack when installing the switch.

### 3.3.2 Mounting the Brackets

- (1) Remove two L-brackets and eight 10-32 UNF x 16PFMHZn cross flat head machine screws from packing materials.
- (2) Position an L-bracket against one side of the chassis and secure the bracket to the chassis with four screws. Position four M6 cage nuts behind mounting holes in the guide rails before securing 10-32 UNF x 16PFMHZn cross flat head machine screws. Repeat this step with the other bracket on the opposite side of the chassis.

**Figure 3-2** Installing the Cage Nuts

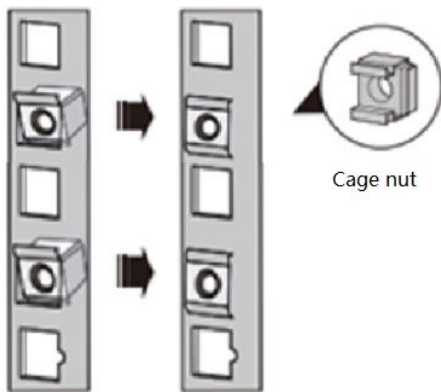

**Figure 3-3 Installing the Guide Rails**

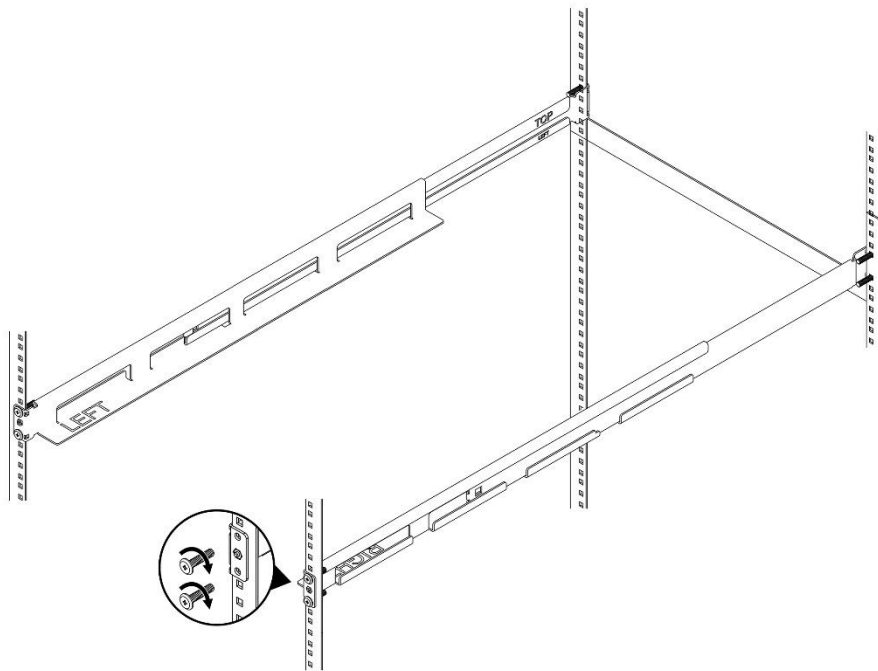

### 3.3.3 Mounting the Chassis on the Rack

The chassis can be installed on a standard 19-inch EIA rack. Mount the chassis on the rack with its front panel facing forward. You are advised to use a tray or guide rails to assist in installing the chassis on the rack.

**Figure 3-4 Mounting the Chassis on the Rack**

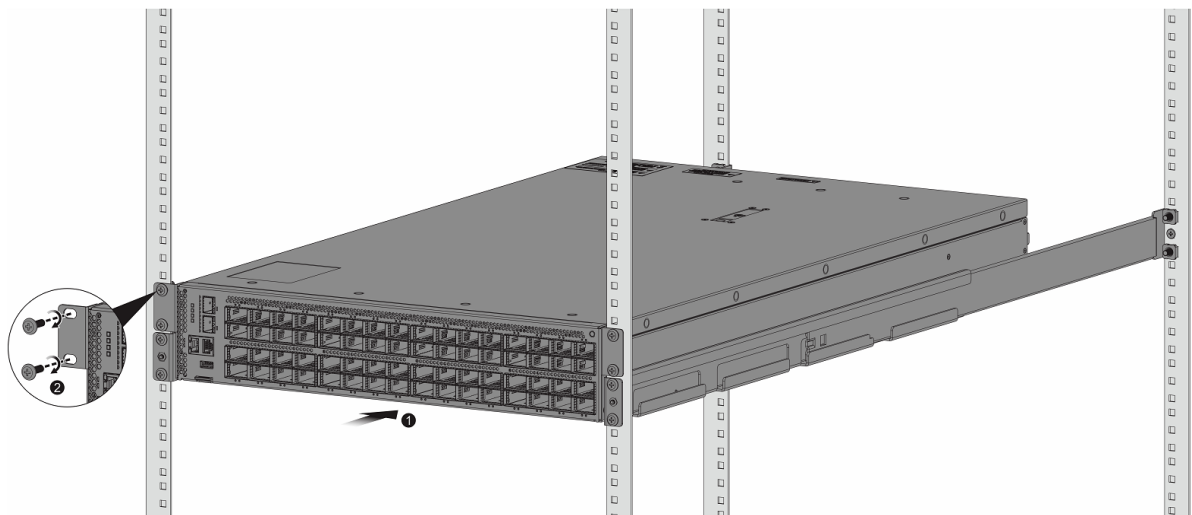

**⚠ Caution**

- Install the L-bracket by driving screws into the four among six screw holes on each side.
- Distinguish left and right rack-mount guide rails according to the notations.
- The rack-mount guide rails delivered with the chassis are applicable to a cabinet with a depth ranging from 800 mm (31.50 in.) to 1,200 mm (47.24 in.).

## 3.4 Installing the Protective Grounding Wire

### 3.4.1 Installation Guidelines

A reliable grounding system is the basis for stable and reliable operation, which is indispensable for preventing lightning strikes and interference. The chassis has a grounding stud on its rear panel. Connect the grounding stud to the grounding terminal of the rack and then connect the grounding terminal to the grounding bar of the equipment room.

- The cross-sectional area of the grounding wire is determined by the maximum possible current. The grounding wire should be of a good conduction quality.
- Never use bare wires.
- The combined grounding should have a grounding resistance of less than 1-ohm.

### 3.4.2 Procedure

- (1) Remove the grounding screw on the rear panel.
- (2) Crimp one end of the grounding wire to the grounding terminal of the chassis and the other end to the grounding terminal of the rack or the grounding bar of the equipment room.

#### **Danger**

- To ensure personal and equipment safety, it is necessary to ground the switch properly. The resistance between the chassis and the ground must be less than 0.1-ohm.
- The maintenance personnel should check whether the AC power socket is reliably connected to the building's protective ground. If not, the maintenance personnel should use a protective grounding wire to connect the protective ground terminal of the AC power socket to the building's protective ground.
- The power cord must be plugged into the power socket connected to the earth ground.
- The power socket must be installed near the equipment in an easily accessible location.
- When installing or replacing the unit, the ground connection must always be made first and disconnected last.

## 3.5 Installing and Removing the Fan Module

Wear an ESD-preventive glove before proceeding with the following operation.

### 3.5.1 Installing the Fan Module

- (1) Remove a fan module from its packing materials.
- (2) Hold the fan module by its handle. Position the fan module in front of the open fan slot. Slide the fan module all the way into the slot until its front side comes in contact with the chassis.

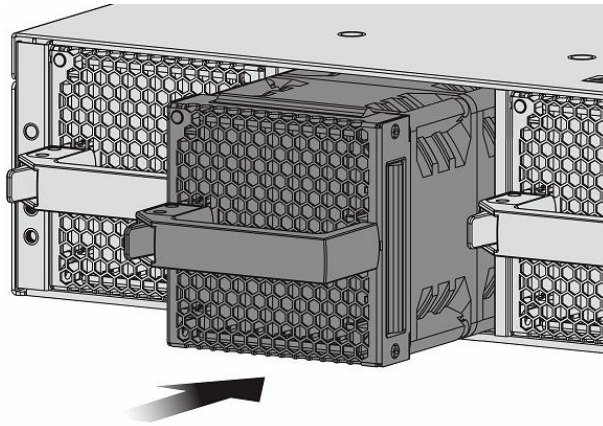
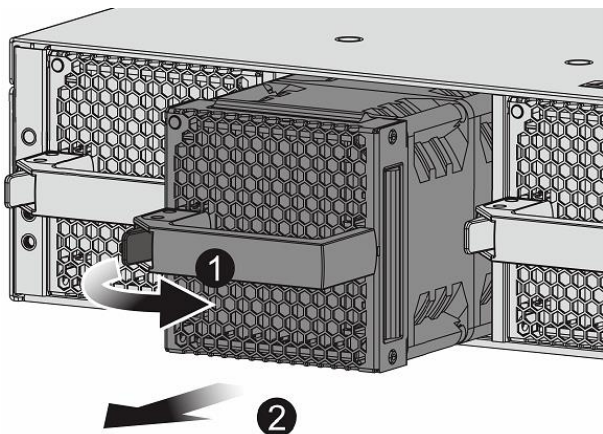

**Figure 3-5 Installing the Fan Module****! Warning**

- Slide the fan module all the way into the chassis gently. Align the fan module in the right orientation to the open fan slot.
- If you are not able to push the fan module all the way into the slot, carefully slide the module out of the slot and repeat step 2 to reinstall the module.
- All fan and power modules must have the same airflow direction or else an error can occur.

**3.5.2 Removing the Fan Module**

- (1) Unlatch the fan module.
- (2) Grasp the handle on the fan module and slide the module out of the slot.
- (3) Install the blank filler plate in the empty slot. Put the removed module back into its packing materials.

**Figure 3-6 Removing the Fan Module****! Warning**

- Pull the fan module out of the slot gently.
- If the fan module slot is to remain empty, install a blank filler plate to allow for adequate airflow and to keep dust out of the chassis.

## 3.6 Installing and Removing the Power Module

Wear an ESD-preventive glove before proceeding with the following operation.

### 3.6.1 Installing the Power Module

- (1) Remove the power module from its packing materials. Make sure the input indicators meet the requirements.
- (2) Remove the blank filler plate from the slot by unscrewing the captive screw. Keep the panel with the nameplate facing upwards. Grasp the handle with one hand and place your other hand underneath the power module to support it. Slide the power module along the guide rails into the slot until the module plugs into the receptacle at the back of the slot.

**Figure 3-7** Installing the Power Module

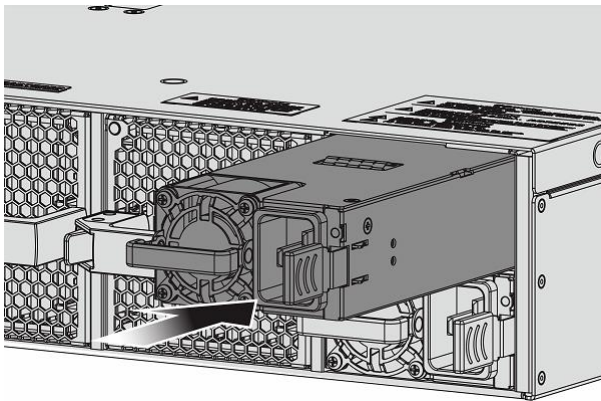

---

**Warning**

- Slide the power module all the way into the chassis gently. Align the power module in the right orientation to the open power slot.
  - If you are not able to push the power module all the way into the slot, carefully slide the module out of the slot, align the module with guide rails, and reinstall the module.
- 

### 3.6.2 Removing the Power Module

- (1) Disconnect the power cord from the power module.
- (2) Press the latch on the power module and pull it halfway out of the slot. Grasp the power module by the handle and gently pull it straight out of the slot, keeping your other hand under the power module to guide it.
- (3) Install the blank filler plate in the empty slot. Put the removed module back into its packing materials.

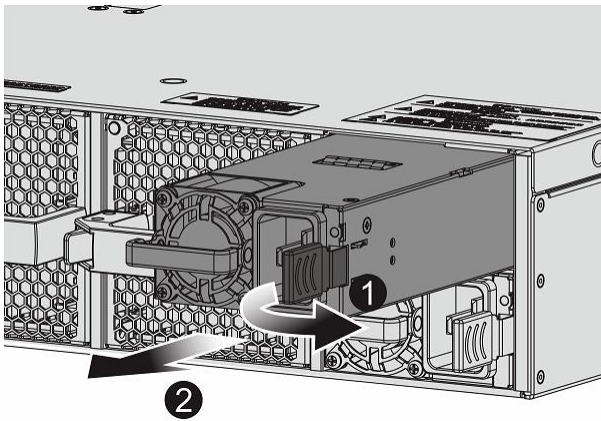
**Figure 3-8 Removing the Power Module****! Warning**

- Pull the power module out of the slot gently.
- If the power module slot is to remain empty, install a blank filler plate to allow for adequate airflow and to keep dust out of the chassis.

### 3.7 Installing the Optical Transceiver

**i Note**

- Make sure that you have mounted the chassis on the rack before installing the optical transceiver.
- For procedure, see *Micas Optical Transceiver Hardware Installation and Reference Guide* for details. The documentation is subject to update without prior notification. Please access Micas Networks at <https://www.Micasnetworks.com/> for details.

### 3.8 Verifying Installation

**⚠ Caution**

Before verifying installation, make sure that all power supplies are turned off.

- The external power supply matches the power distribution system.
- The front and rear doors of the rack can close properly after installation has been completed.
- The rack has been completely fastened, which will not move or tilt.
- The chassis has been mounted on the rack and all cables have been fastened to the rack.
- Select the proper fan module and tighten captive screws.
- Select the proper power module.
- The power module is completely seated in the slot.
- At least two personnel are required to power on the chassis. Do not service the chassis before it is powered off.

- Carefully check your work area for possible hazards, such as ungrounded power extension cables, missing safety grounds, and moist floors.
- Do not subject the equipment to dampness and avoid liquid inside the equipment.
- Locate the emergency power-off switch in the room. In the case of an electrical accident, you will be able to quickly turn off the power.
- Never assume that power is disconnected from a circuit. Instead, always check.
- The power cord is plugged into the power module and retained there.
- The power cord is long enough to avoid over-extension.
- The power socket is connected to the earth ground as required with a rated current of at least 10 A.
- Each power module receives power from a power socket.
- If a slot is to remain empty, install a blank filler plate to allow for adequate airflow and to keep dust out of the chassis.

### 3.9 Connecting the Power Cord

Connect the power cord according to the notation on the power module and location requirements. Take the AC power cord as an example:

- (1) Connect one end of the AC power cord to the power connector.
- (2) Connect the other end of the AC power cord to the power socket of the external power system.

---

 **Caution**

- Make sure the power socket is OFF before connecting the power cord.
  - Use a 3-core power cord, with a minimum cross-sectional area of 1.5 mm<sup>2</sup> or 14 AWG per pin.
  - Use a 16 A power cord for the AC power supply. Adopt the proper power socket and make sure that the AC power system in the equipment room is capable enough.
-

# 4 Commissioning

## 4.1 Setting Up the Configuration Environment

Connect the serial port of a PC to the console port of the device with a cable, as shown in [Figure 4-1](#).

**Figure 4-1 Configuration Environment**

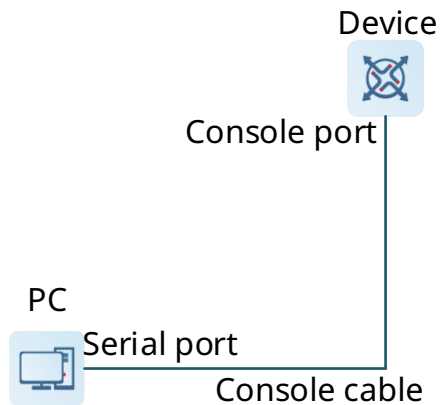

The first login to the device must be performed through the console port.

- (1) Connect the serial port of a PC to the console port of the device with a standard RS-232 cable.
- (2) Set up a local configuration environment through the console port on the front panel.
- (3) Configure communication parameters of the terminal. Run a terminal emulation software such as PuTTY:
  - a Launch PuTTY to enter its main interface.

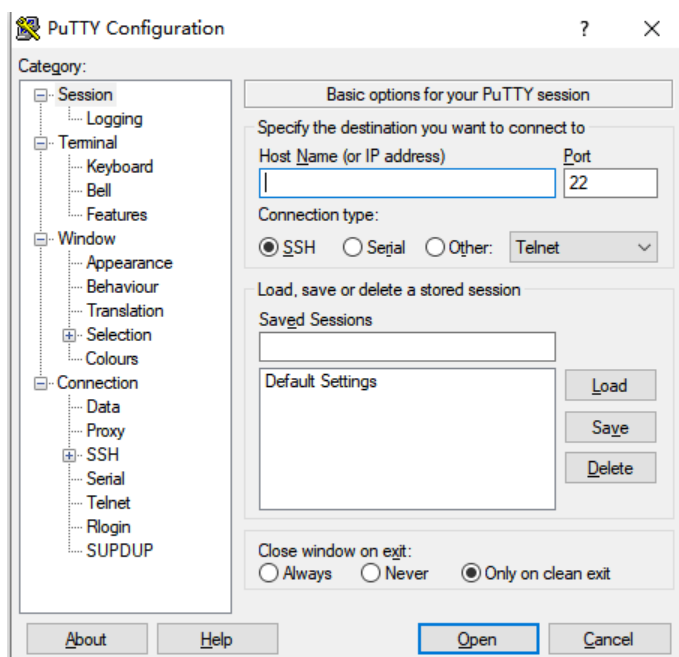

- b** Click **Serial** in the left column. Set **Bits per second** to **115,200**, **Data bits** to **8**, **Parity** to **None**, **Stop bits** to **1**, and **Flow control** to **None**.

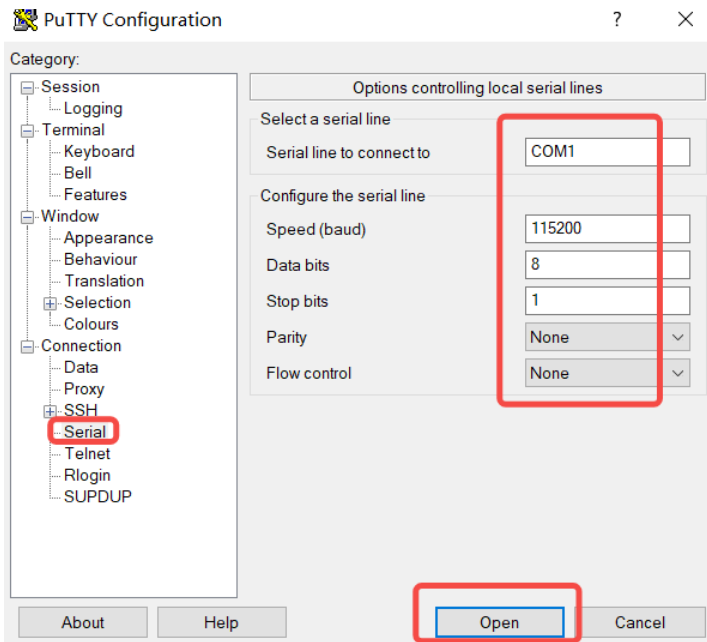

- c** Click **Open** to set up the connection.



- (4) After setting up the configuration environment, power on the device. If the device is already configured with a password, a notification will appear. Click **Accept**, and enter your username and password for connection.

## 4.2 Powering on the Device

### 4.2.1 Checklist Before Power-on

- The switch is connected to earth ground.
- The fan and power modules are properly installed.
- The power cord matching the power module is connected properly.
- The input voltage follows the requirement.

- Check whether the cable is properly connected, whether the terminal such as a PC is started, and whether terminal parameters are configured.

### **4.2.2 Power-on**

Turn off the circuit breaker at the power supply end and set the power switch of the chassis to ON.

### **4.2.3 Checklist Before Power-on**

- The cooling system operates normally.
- There is information output on the terminal interface.
- The LED status is normal.

# 5 Monitoring and Maintenance

## 5.1 Monitoring

### 5.1.1 Monitoring the LEDs

Each module installed in the chassis features a LED, which can be used to monitor the status of each module while the switch is running. See [Overview](#) for details.

**Table 5-1 Faults Indicated by LEDs**

LED Status	Fault Symptom	Suggested Action
The system status LED is red.	The system generates a critical temperature about temperature.	Log in to the management software for troubleshooting. Cut off the power supply if necessary.
The system status LED is yellow.	The system is functioning but with a temperature anomaly.	
The fan status LED is off or red.	The system is functioning but with a fan anomaly.	
The power status LED is off or red.	The power module is not functioning properly.	

### 5.1.2 Running the CLI Commands

You can run CLI commands to monitor the following status:

- Whether the chassis is operating normally and whether all modules are properly installed
- Port configuration and status
- Fan and power module status
- System temperature

---

**Note**

- See *Command Reference* for monitoring commands.
  - You can log in to the device through Telnet or SSH for maintenance by running CLI commands.
- 

## 5.2 Maintenance

### 5.2.1 Replacing the Power Module

The power failure will be prompted through monitoring signals. In the case of a power failure, contact your distributor or technical support team.



See [3.6 Installing and Removing the Power Module](#) for procedure.

---

**⚠ Caution**

- After hot swapping a power module, wait for at least 30 seconds before proceeding with next hot swapping operation.
  - Make sure that the chassis is secured to avoid the chassis falling down during power module swapping.
  - Avoid the contact between the edge connector of the removed power module and human body to prevent the danger of electric shocks.
- 

## 5.2.2 Replacing the Fan Module

The fan failure will be prompted through monitoring signals. In the case of a fan failure, contact your distributor or technical support team.

See [3.5 Installing and Removing the Fan Module](#) for procedure.

---

**⚠ Caution**

- The fan module supports hot standby. Although the system keeps operating normally for a period even after a fan module fails, you are advised to replace the fan module immediately.
  - Tighten the captive screw on the fan module.
  - Wait until the fans stop rotating before removing the fan module. Do not protrude your fingers into the fan module.
  - After the fan module is removed from an operating chassis, install a new fan module immediately to ensure normal operation and to avoid equipment damage.
- 

## 5.2.3 Replacing the Lithium Battery

The equipment has a built-in lithium battery to maintain the real-time clock without external power supply.

To replace the lithium battery, please contact your distributor or technical support team.

**⚡ Danger**

- There is the danger of explosion if the battery is replaced incorrectly. Replace the battery only with the same or equivalent type recommended by the manufacturer.
- Dispose the replaced lithium battery properly. Subjecting the battery to extremely high temperatures, extremely low air pressure, fire, or microwave oven may cause flammable liquid or gas leakage or even the danger of explosion.

## 5.2.4 Replacing the Fuse

To replace the fuse, please contact your distributor or technical support team. Authorized personnel from Micas Networks will replace the fuse according to the model and rating corresponding to the fuse bits. The fuse specifications are indicated near the fuse. Replacing a fuse with one of the different specifications may cause equipment damage, personal injury, or property loss. The fuse specifications are list as follows.

**Table 5-2 Fuse Specifications**

Model	Fuse Bits	Specifications
M2-W6940-64OC-BASE	F2,F4	F 4 AL/125 V DC
M2-W6940-64OC-BASE	F5	F 15 AL/125 V DC
M2-W6940-64OC-MGMT	F1	F 4 AL/125 V DC
M2-W6940-64OC-FAN	F1,F2,F3,F4	F 40 AL/125 V DC
M2-W6940-64OC-MAC	F1,F2,F3,F4	F 100 AL/72 V DC

---

**⚠ Caution**

- Do not repair the fuse on site. Instead, deliver it to the factory for repair.
  - To avoid fire hazards, always replace a blown fuse with one of the same model and specifications.
-

# 6 Troubleshooting

## 6.1 Flowchart

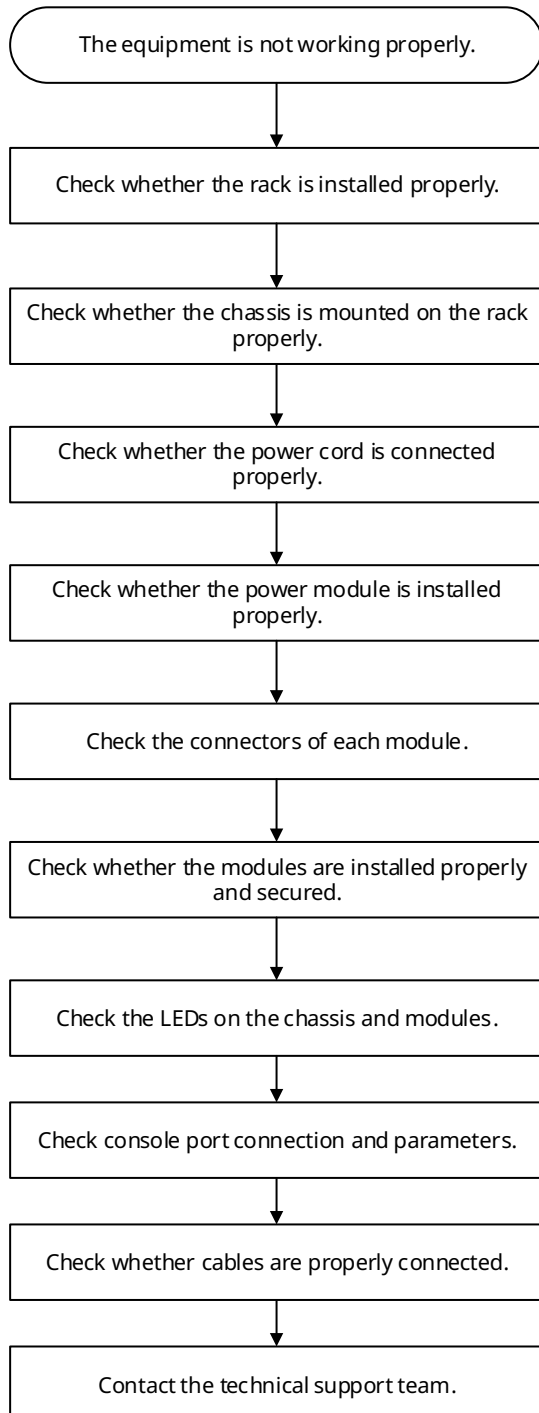

## 6.2 Common Issues

### 6.2.1 Forgetting Login Password

#### Symptom

The login password is forgotten.

#### Handling Method

Contact technical support team.

### 6.2.2 AC Power Module Failure

#### Symptom

All LEDs on the front panel are off. The fan status LED is off, and the fan does not rotate.

#### Handling Method

- (1) Unplug the power cord from the power module.
- (2) Check whether the power cord is securely connected to the power socket.
- (3) Check whether the power cord is securely connected to the power module.
- (4) Check whether the power module is securely seated. If necessary, pull out the power module and check its connector.
- (5) Check whether the power cord matches the power supply.

### 6.2.3 Fan Module Not Rotating

#### Symptom

After the system is powered on, the fan does not rotate or the fan status LED is not on.

#### Handling Method

Check whether the fan module plugs into the receptacle at the back of the slot. If yes, please replace the fan module.

### 6.2.4 No Output on the Console

#### Symptom

After the system starts, there is no output on the console.

#### Handling Method

Check whether the console cable is properly connected. Ensure that the connected serial port is consistent with what is configured on the HyperTerminal and that the configuration of the serial port on the HyperTerminal is consistent with that in *Configuration Guide*. If there is still no console output, contact technical support team.

### 6.2.5 Garbled Output on the Console

#### Symptom

The console output is garbled.

#### Handling Method

The fault is related to the serial port configuration. Check whether baud rate configuration is consistent with that in *Configuration Guide*.

## 6.2.6 Optical Port Linkdown

### Symptom

The system runs normally. After you insert an optical transceiver into an optical port and plug in an optical cable, the link cannot be set up.

### Handling Method

- a** Check whether the receive and transmit ends are reversed. The transmit end of an optical port must be connected to the receive end of the peer port. You can confirm both ends by exchanging the connection order of two optical cables.
- b** Check whether wavelengths of optical transceivers on both sides are consistent. For example, an optical transceiver with a wavelength of 1310 nm cannot be connected to an optical transceiver of 1550 nm.
- c** Check whether the distance between two sides exceeds the maximum length marked on the optical transceiver.
- d** Check whether the speeds of two sides are consistent and whether the optical cable type meets requirements. For ports supporting different speeds, check their speed settings.

# 7 Appendix

## 7.1 Labeling Process

### 7.1.1 Hand Writing on Labels

Writing tool: black gel pen

### 7.1.2 Pasting Labels

Fill in the label content on the full-page label paper before attaching the label, and then paste it on the power cord or signboard wire buckle.

#### (1) Label pasting position

Paste the label 2 cm (0.79 in.) away from the plug. In some specific situations, avoid cable bending or the position that affects power cord installation. The label is pasted on the power cord with the long text area always facing right or downwards, as shown in [Figure 7-1](#). The flowchart is described as follows:

- a** At the label attachment, keep the label facing right when the power cable is laid vertically.
- b** Keep the label facing downwards when the power cord is laid horizontally.

**Figure 7-1 Keeping the Label Text Area Facing Right or Downwards**

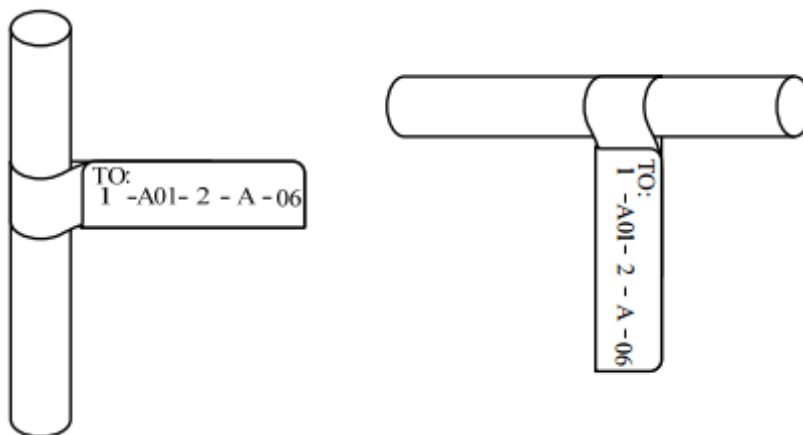

#### (2) Labeling procedure

**Figure 7-2 Signal Cable Labeling Procedure**

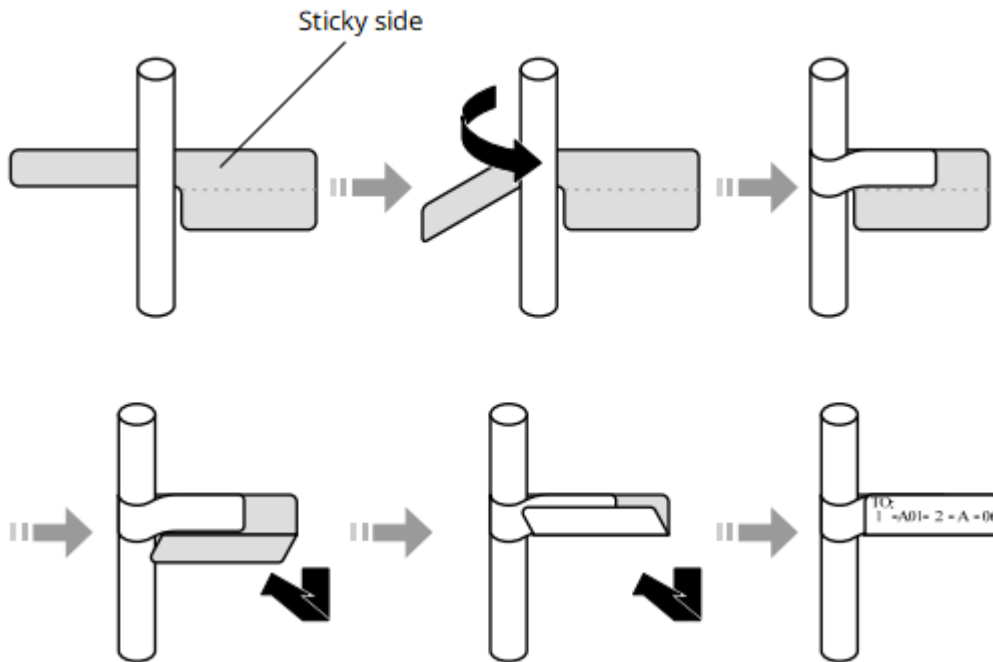

### 7.1.3 Label Contents

The contents of the two sides of the label identify the location of the ports connected to the two ends of the power cord. Fill in the label according to the specific environment.

- (1) Fill the content of the local end of the cord location in area ①.
- (2) Fill the content of the remote end of the cord location in area ②.
- (3) Area ③ is collapsed when the label is pasted.

**Figure 7-3 Signal Cable Label**

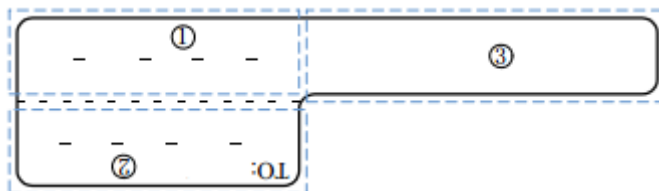

## 7.2 Connectors and Media

### 7.2.1 100BASE-TX/10BASE-T Port

**Table 7-1 100BASE-TX/10BASE-T Pin Assignment**

Pin	MDI Mode	MDI-X Mode
1	Output Transmit Data+	Input Receive Data+
2	Output Transmit Data-	Input Receive Data--
3	Input Receive Data+	Output Transmit Data+

Pin	MDI Mode	MDI-X Mode
6	Input Receive Data-	Output Transmit Data-
4, 5, 7, 8	Not Used	Not Used

The following figure shows 100BASE-TX/10BASE-T straight-through and crossover cables.

**Figure 7-4 100BASE-TX/10BASE-T Twisted Pairs**

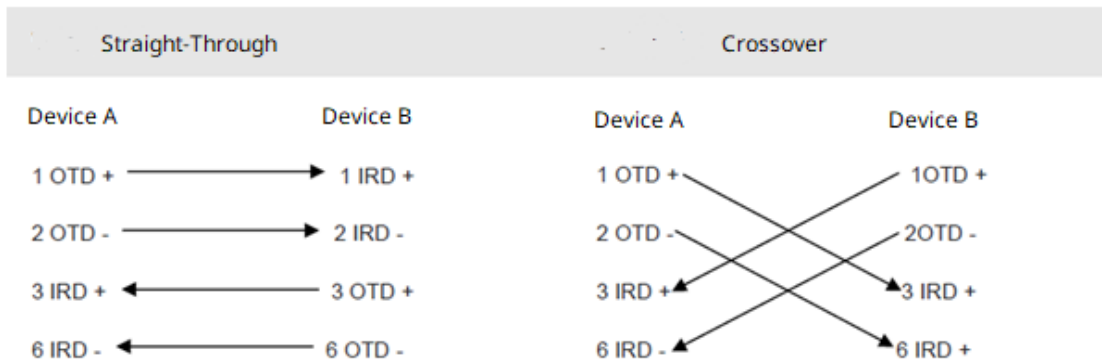

### 7.2.2 1000BASE-T Port

Compliant with the IEEE 802.3ab standard, 1000BASE-T requires CAT5, CAT5e or higher standard 100-ohm twisted pairs with a distance of up to 100 meters (328.08 ft.). The 1000BASE-T port employs four pairs of wires for data transmission. [Figure 7-5](#) shows the twisted pair connection for the 1000BASE-T port. The connection method and signal description are provided considering self-made cables. Keep the side without the RJ45 locking clip facing yourself. The signal cables are numbered 1 to 8 from left to right.

**Figure 7-5 Cable Connection Modes and Signals**

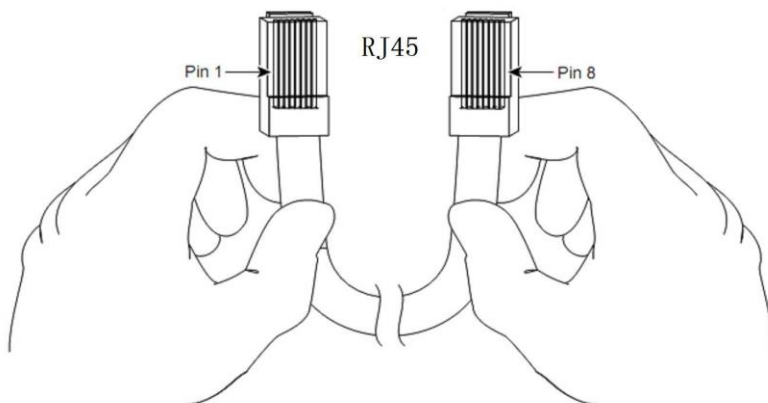

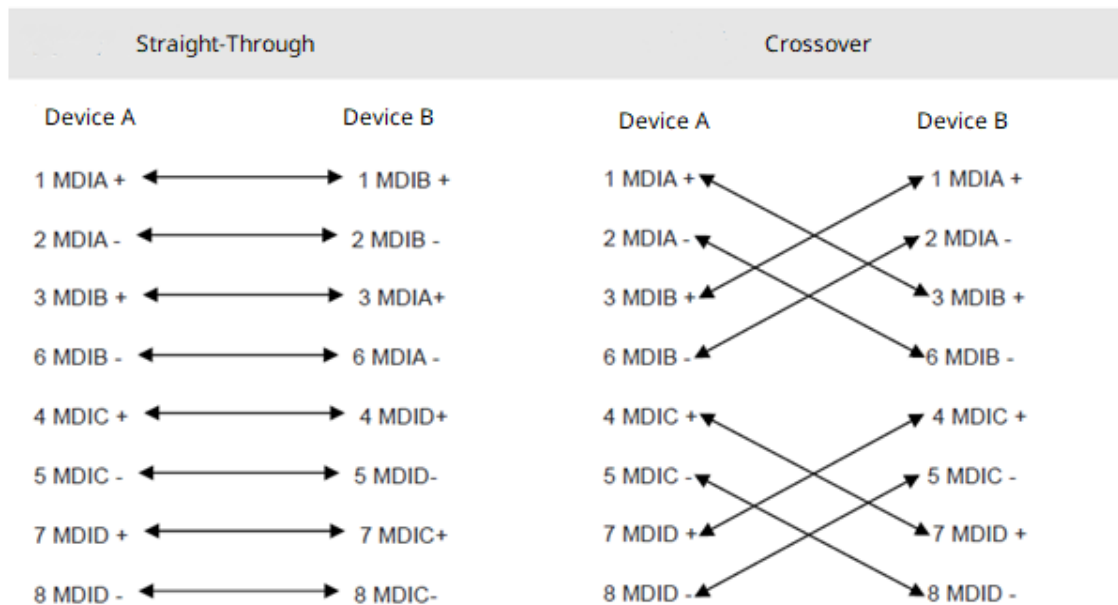

**Table 7-2 1000BASE-T Pin Assignment**

Pin	MDI Mode	MDI-X Mode
1	Media Dependent Interface A+	Media Dependent Interface B+
2	Media Dependent Interface A-	Media Dependent Interface B-
3	Media Dependent Interface B+	Media Dependent Interface A+
4	Media Dependent Interface C+	Media Dependent Interface D+
5	Media Dependent Interface C-	Media Dependent Interface D-
6	Media Dependent Interface B-	Media Dependent Interface A-
7	Media Dependent Interface D+	Media Dependent Interface C+
8	Media Dependent Interface D-	Media Dependent Interface C-

The 1000BASE-T port employs all four pairs of wires for data transmission. [Figure 7-6](#) shows the twisted pair connection for the 1000BASE-T port.

**Figure 7-6 1000BASE-T Twisted Pair Connections**



## 7.3 Surge Protection

### 7.3.1 Installing an AC Power Arrester

When an AC power cord from outdoors is directly plugged into the power port of the switch, the AC power connector must be connected to an external surge protector power strip to protect the switch against lightning strikes. The surge protector power strip can be fixed on the rack, workbench, or wall in the equipment room by using cable ties and screws. AC power enters the switch through the surge protector power strip. AC power enters the switch through the surge protector power strip.

**Figure 7-7 Power Arrester**

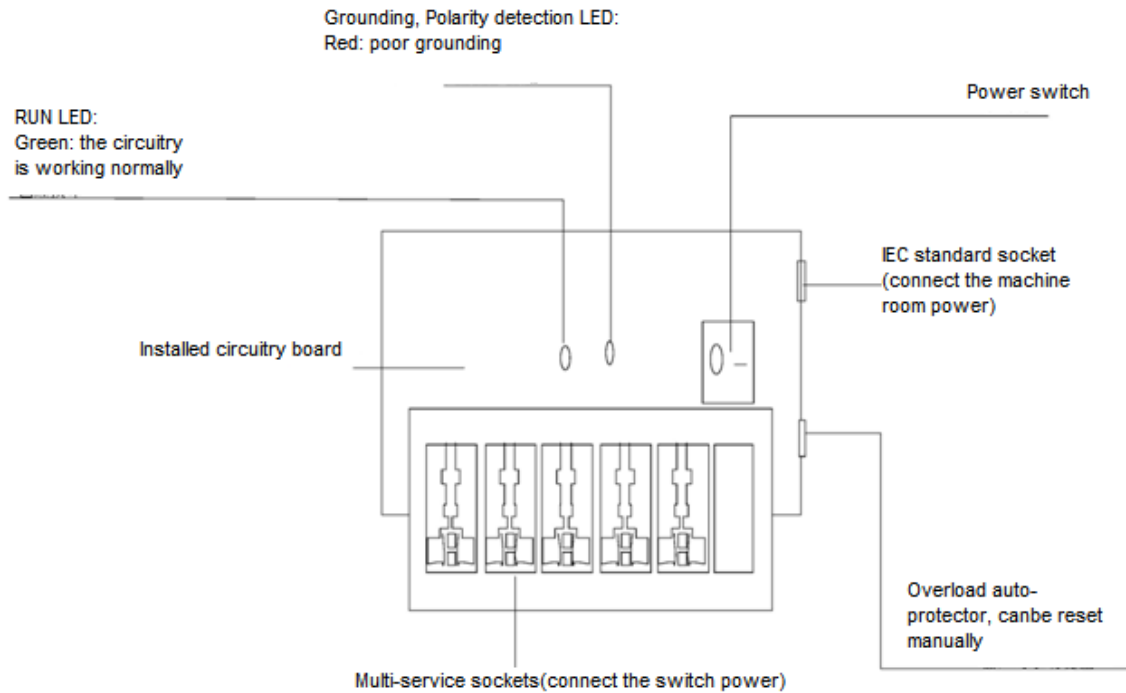

#### **Note**

The power arrester does not come with the equipment. Please purchase it based on actual requirements.

Important points:

- Make sure that the PE terminal of the power arrester is well grounded.
- After the AC power plug of the switch is connected to the socket of the power arrester (surge protector power strip), the surge protection function is implemented only if the LED indicating operation status is green and the LED indicating alarm status is OFF.
- If the LED on the power arrester turns red, check whether it is caused by poor grounding connection or by the reversed connection of the null and live lines. The detection method is as follows: Use a multimeter to measure the polarity of the power socket for the arrester when the LED turns red. If the null line is on the left and the live line is on the right (facing the socket), the arrester's PE terminal is not grounded. If not, the null and live lines are reversed. In this case, you should open the power arrester and reverse the null and live lines. If the LED is still red, the arrester's PE terminal is not grounded.

### 7.3.2 Installing an Ethernet Port Arrester

Please connect an Ethernet port arrester to the switch to prevent the damage by lightning before connecting an outdoor network cable to the switch.

Tools: Phillips screwdrivers or flat-head screwdriver, multimeter, and diagonal pliers

Procedure:

- (1) Tear one side of the protective paper for the double-sided adhesive tape and paste the tape to the enclosure of the Ethernet port arrester. Tear the other side of the protective paper for the double-sided adhesive tape and paste the Ethernet port arrester to the switch enclosure. The paste position for the Ethernet port arrester should be as close to the grounding terminal of the switch as possible.
- (2) According to the distance between the switch grounding terminal and the Ethernet port arrester, trim the grounding wire for the Ethernet port arrester and firmly crimp the grounding wire to the grounding lug of the switch.
- (3) Use a multimeter to check whether the grounding wire for the arrester is in good contact with the grounding terminal and the enclosure of the switch.
- (4) Connect the arrester by using an adapter cable (note that the external network cable is connected to the IN end, while the adapter cable connected to the switch is connected to the OUT end) and check whether the service module LED is normal.
- (5) Use a nylon cable tie to bundle the power cords.

**Figure 7-8 Installing an Ethernet Port Arrester**

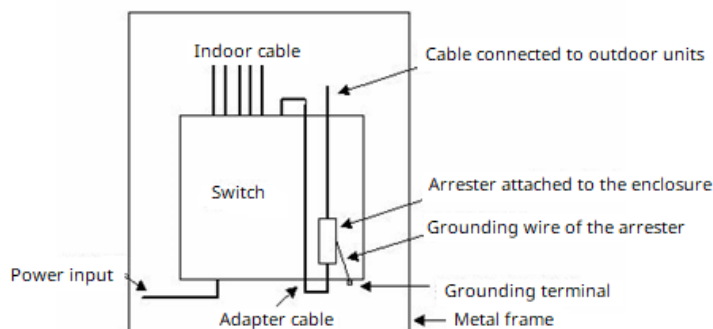

#### **Note**

- The Ethernet port arrester is only for the 10/100BASE-T Ethernet port with an RJ-45 connector.
- The Ethernet port arrester is not delivered with the switch. Please purchase it as required. The Ethernet port arrester user manual contains technical parameters and maintenance and installation instructions for the Ethernet port arrester. Carefully read this manual before installation.

Caution is needed to avoid the following cases:

- Reversed installation direction of the arrester. Connect the external network cable to the **IN** end and connect the Ethernet port of the switch to the **OUT** end.
- Poor grounding of the arrester. The grounding wire of the arrester should be as short as possible to ensure that it is in good contact with the grounding terminal of the switch. Use a multimeter to confirm the contact condition after grounding.

- Incomplete arrester installation. If there is more than one port connected to external power cords, arresters need to be installed on all connection ports for the purpose of surge protection.

## 7.4 Site Selection

- The equipment room should be at least 5 km (16,404.20 ft.) away from heavy pollution sources, such as the smelter works, coal mine, and thermal power plant. The equipment room should be at least 3.7 km (12,139.11 ft.) away from medium pollution sources, such as the chemical factory, rubber factory, and electroplating factory. The equipment room should be at least 2 km (6,561.68 ft.) away from light pollution sources, such as the food factory and leather plant. If the pollution source is unavoidable, the equipment room should be located on the windward side of the pollution source perennially with advanced protection.
- The equipment room should be at least 3.7 km (12,139.11 ft.) away from the sea or salt lake. Otherwise, the equipment room must be sealed, with air conditioner installed for temperature control. Saline soil cannot be used for construction. Otherwise, you should select equipment with advanced protection against severe environment.
- Do not build the equipment room in the proximity of livestock farms. Otherwise, the equipment room should be located on the windward side of the pollution source perennially. The previous livestock house or fertilizer warehouse cannot be used as the equipment room.
- The equipment room should be firm enough to withstand severe weather conditions such as windstorm and heavy rain as well as away from dust. If the dust is unavoidable, keep the door and window away from the pollution source.
- The equipment room should be away from the residential area. Otherwise, the equipment room should meet the construction standard in terms of noise.
- Make sure the air vent of the equipment room is away from the sewage pipe, septic tank, and sewage treatment tank. Keep the equipment room under positive pressure to prevent corrosive gas from entering the equipment room to corrode components and circuit boards.
- Keep the equipment room away from industrial boiler and heating boiler.
- The equipment room should be on the second floor. Otherwise, the equipment room floor should be 600 mm (23.62 in.) higher than the highest flood level ever recorded.
- Make sure there are no cracks or holes in the wall and floor. If there are cable entries in the wall or window, take proper sealing measures. Ensure that the wall is flat, wear-resistant, and dust-free, which should be up to the standard for flame retarding, soundproofing, heat absorption, dust reduction, and electromagnetic shielding.
- Keep the door and the window closed to make the equipment room sealed.
- The steel door is recommended for soundproofing.
- Sulfur-containing materials are forbidden.
- Keep the air conditioner from blowing wind straight toward the equipment or blowing water drops from the window or air vent toward the equipment.

## 7.5 Recommended Cabling

When the switch is installed in a standard 19-inch rack, route the cables through the cable management brackets. Top cabling or bottom cabling is adopted according to the actual situation in the equipment room. All conversion connectors should be placed at the bottom of the rack instead of outside the rack that is easily accessible. Power cords are routed beside the rack, and top cabling or bottom cabling is adopted

according to the locations of the AC power socket, or surge protection box in the equipment room.

- Requirements for the Minimum Bend Radius of Ethernet Cables
  - The bend radius of a fixed power cord, Ethernet cable, or flat cable should be over five times greater than their respective diameters. The bend radius of these cables that are often bent or plugged should be over seven times greater than their respective diameters.
  - The bend radius of a fixed common coaxial cable should be over seven times greater than its diameter. The bend radius of the common coaxial cable that is often bent or plugged should be over 10 times greater than its diameter.
  - The bend radius of a fixed high-speed cable (such as SFP+ cable) should be over five times greater than its diameter. The bend radius of the fixed high-speed cable that is often bent or plugged should be over 10 times greater than its diameter.
- Requirements for the Minimum Bend Radius of Optical Cables
  - The diameter of a fiber splice tray to hold fibers should be over 25 times greater than the diameter of the fiber.
  - When an optical cable is moved, the bend radius of the optical cable should be over 20 times greater than the diameter of the optical cable.
  - During cabling, the bend radius of the optical cable should be over 10 times greater than the diameter of the optical cable.
- Precautions for Bundling up Cables
  - Before cables are bundled, mark labels and paste the labels to cables.
  - Cables should be neatly and properly bundled in the rack without twisting or bending.

**Figure 7-9 Bundling Up Cables (1)**

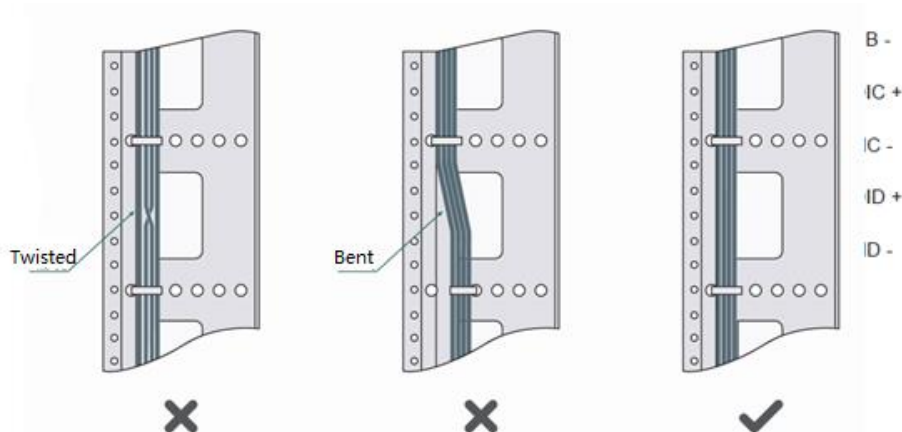

- Cables of different types (such as power cords, signal cables, and grounding wires) should be separated in cabling and bundling. Mixed bundling is not allowed. When they are close to each other, you are advised to adopt crossover cabling. In the case of parallel cabling, maintain a minimum distance of 30 mm (1.18 in.) between power cords and signal cables.
- The cable management brackets and chute inside and outside the rack should be smooth without sharp corners.

- The metal hole traversed by cables should have a smooth and fully rounding surface or an insulated lining.
- Use cable ties to bundle up cables properly. Please do not connect two or more cable ties to bundle up cables.
- After bundling up cables with cable ties, cut off the remaining part. The cut should be smooth and trim, without sharp corners, as shown in [Figure 7-10](#).

**Figure 7-10 Bundling Up Cables (2)**

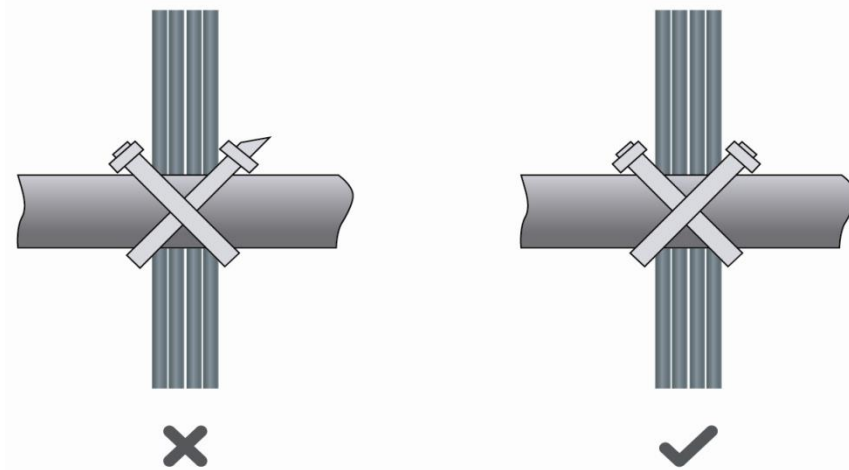

- When cables need to be bent, please bundle them up but do not tie them where the cables will be bent, as shown in [Figure 7-11](#).

**Figure 7-11 Bundling Up Cables (3)**

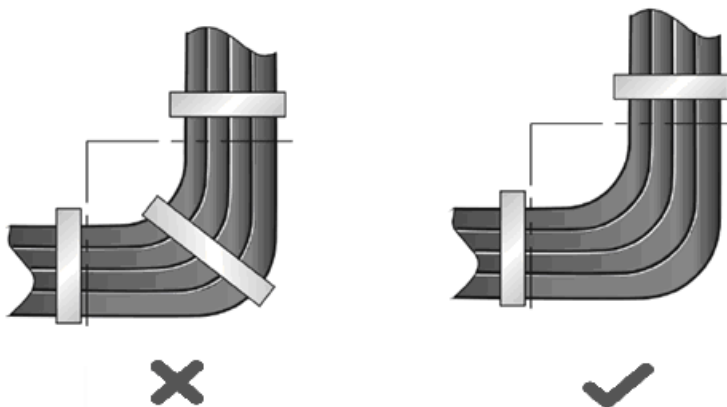

- Cables not to be assembled or remaining parts of cables should be folded and placed in a proper position of the rack or cable trough. The proper position refers to a position that does not affect switch performance or damage the switch or cable.
- 220 V and -48 V power cords must not be bundled on the guide rails of moving parts.
- Leave a margin for the power cords connecting moving parts such as door grounding wires after they are connected to avoid suffering tension or stress. When the moving part is installed, the remaining cable part should not touch heat sources or sharp corners. If heat sources cannot be avoided, high-temperature cables should be adopted.
- For the cable terminals fastened by screw threads, tighten the bolt or screw and take cable retention measures, as shown in [Figure 7-12](#).

**Figure 7-12 Cable Fastening**

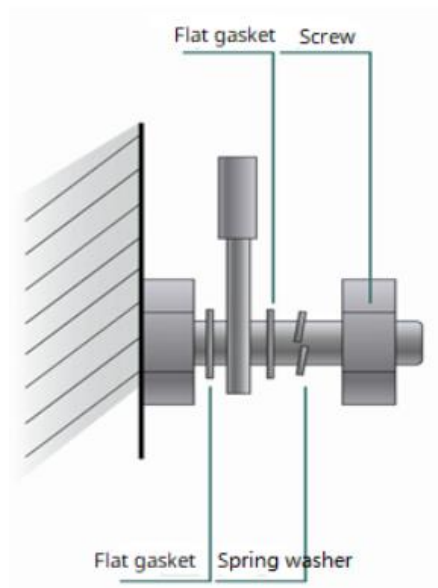

- Hard power cords should be fastened in the terminal connection area to prevent stress on terminal connection and cable.
- Do not use self-tapping screws to fasten terminals.
- Power cords of the same type and in the same cabling orientation should be bundled up into one cable bundle. The power cords in the bundle should be clean and straight.
- Bundle up cables by using cable ties.

**Table 7-3 Cable Bundling**

Cable Bundle Diameter	Distance between Every Binding Point
10 mm (0.39 in.)	80 mm to 150 mm (3.15 in. to 5.91 in.)
10 mm to 30 mm (0.39 in. to 1.18 in.)	150 mm to 200 mm (5.91 in. to 7.87 in.)
30 mm (1.18 in.)	200 mm to 300 mm (7.87 in. to 11.81 in.)

- No knot is allowed in cabling or bundling.
- For wiring terminal blocks (such as circuit breakers) with insulated terminals, the metal part of the insulated terminal should not be exposed outside the terminal block during assembling.