

Micas M2-W6010 Switch

Hardware Installation and Reference Guide

Document version: V2.0

Date: August 31, 2023

Copyright © 2024 Micas Networks Inc

Copyright

Copyright © 2024 Micas Networks Inc.

Micas Networks reserves all copyrights of this document.

Any reproduction, excerpt, backup, modification, transmission, translation, or commercial use of this document or any portion of this document, in any form or by any means, without the prior written consent of Micas Networks is prohibited.

All other trademarks or registered trademarks mentioned in this document belong to their respective owners.

Disclaimer

The purchased products, services, and features are stipulated by the contract made between Micas Networks and the customers. All or part of the products, services, and features described in this document may not be within the purchase scope or the usage scope. Unless otherwise specified in the contract, all statements, information, and recommendations in this document are provided "AS IS" without warranties, guarantees, or representations of any kind, either express or implied.

The information in this document is subject to change without notice. Micas Networks reserves the rights to change the content without any notice or warning.

This document is used only for reference. Micas Networks endeavors to ensure that the content in this document is accurate and reliable, but cannot ensure that no error or omission exists. All information in this document does not constitute any expressed or implied warranty.

Micas

Website: <https://www.micasnetworks.com/>

Customer service email: support@micasnetworks.com

Preface

Intended Audience

This document is intended for:

- Network engineers
- Technical support and servicing engineers
- Network administrators

Technical Support

Official Website: <https://www.micasnetworks.com/support/>

Signs

The signs used in this document are described as follows:

 **Danger**
An alert that contains important safety instructions. Before you work on any equipment, be aware of the hazards involved and be familiar with standard practices for preventing accidents.

 **Warning**
An alert that calls attention to important rules and information that if not understood or followed can result in data loss or equipment damage.

 **Caution**
An alert that calls attention to essential information that if not understood or followed can result in function failure or performance degradation.

 **Note**
An alert that contains additional or supplementary information that if not understood or followed will not lead to serious consequences.

 **Specification**
An alert that contains a description of product or version support.

Note

- The port type involved in this manual may be different from the actual situation. Please proceed with configuration according to the port type supported by the product.

- The display information involved in this manual may contain the content of other products (such as model and description). Please refer to the actual display information.
- The routers and router product icons involved in this manual represent common routers and Layer 3 switches capable of routing protocols.

Contents

Preface	1
1 Overview	1
1.1 About the M2-W6010 Series	1
1.2 Component Modules.....	1
1.3 Chassis.....	1
1.3.1 Appearance.....	2
1.3.2 LEDs	4
1.3.3 Ports.....	5
1.3.4 Cooling.....	7
1.3.5 Technical Specifications	8
1.3.6 Asset Tag.....	11
1.4 Cables.....	11
1.4.1 Ethernet Cable.....	11
1.4.2 Power Cord.....	12
1.4.3 Grounding Wire	13
2 Preparing for Installation	14
2.1 Safety Guidelines.....	14
2.1.1 General Precautions.....	14
2.1.2 Chassis-Lifting Guidelines.....	14
2.1.3 Electricity Safety	15
2.1.4 Preventing ESD Damage.....	15
2.1.5 Laser Safety	15
2.1.6 Storage Guidelines	16
2.2 Site Requirements.....	16
2.2.1 Floor Loading	16
2.2.2 Airflow	16
2.2.3 Space	16
2.2.4 Temperature	16
2.2.5 Humidity.....	17
2.2.6 Cleanliness	17

2.2.7 System Grounding.....	18
2.2.8 Preventing Electromagnetic Interference.....	19
2.2.9 Surge Protection.....	19
2.3 Rack-Mounting Guidelines.....	19
2.4 Tools.....	20
2.5 Unpacking the Switch.....	21
2.5.1 Verifying the Shipped Content.....	21
2.5.2 Unpacking the Container.....	21
3 Installing the Switch	24
3.1 Installation Procedure.....	24
3.2 Installing the Rack.....	25
3.2.1 Installation Guidelines.....	25
3.2.2 Procedure.....	25
3.3 Installing the Chassis.....	26
3.3.1 Installation Guidelines.....	26
3.3.2 Mounting the Chassis on the Rack.....	26
3.3.3 Mounting the Chassis on the Workbench.....	27
3.4 Installing the Protective Grounding Wire.....	28
3.4.1 Installation Guidelines.....	28
3.4.2 Procedure.....	28
3.5 Installing and Removing the Pluggable Module.....	29
3.6 Verifying Installation.....	29
3.7 Connecting the Power Cord.....	30
4 Commissioning	31
4.1 Setting Up the Configuration Environment.....	31
4.2 Powering on the Device.....	32
4.2.1 Checklist Before Power-on.....	32
4.2.2 Power-on.....	33
4.2.3 Checklist Before Power-on.....	33
5 Monitoring and Maintenance.....	34
5.1 Monitoring.....	34
5.1.1 Monitoring the LEDs.....	34
5.1.2 Running the CLI Commands.....	34
5.2 Maintenance.....	35

5.2.1 Replacing the Lithium Battery	35
5.2.2 Replacing the Fuse	35
6 Troubleshooting	36
6.1 Flowchart	36
6.2 Common Issues	37
6.2.1 Forgetting Login Password.....	37
6.2.2 AC Power Module Failure	37
6.2.3 Fan Module Not Rotating	37
6.2.4 No Output on the Console	37
6.2.5 Garbled Output on the Console.....	37
6.2.6 Optical Port Linkdown.....	38
7 Appendix	39
7.1 Labeling Process	39
7.1.1 Hand Writing on Labels	39
7.1.2 Pasting Labels	39
7.1.3 Label Contents	40
7.2 Connectors and Media	40
7.2.1 1000BASE-T Port	40
7.2.2 100BASE-TX/10BASE-T Port	42
7.3 Surge Protection.....	43
7.3.1 Installing an AC Power Arrester	43
7.3.2 Installing an Ethernet Port Arrester	44
7.4 Site Selection	45
7.5 Recommended Cabling	45

1 Overview

1.1 About the M2-W6010 Series

The M2-W6010 series switch is a next-generation 1GE switch featuring high-density, and low-latency launched by Micas Networks for data centers and high-end campuses. The M2-W6010 Series switch provides high-density 1GE access, 10GE uplink ports, and diverse data center features. It can be used with the M2-W6500 and M2-W6900 series switch for a high-performance and high-reliability data center network.

Table 1-1 M2-W6010 series Overview

Chassis	10GE Ports	100GE Ports	Expansion Module Slots	Power Redundancy	Fan Redundancy
M2-W6010-48GT4X-FA	48	4	-	1+1	1+1
M2-W6010-48GT4X-RA	48	4	-	1+1	1+1

Note

- The product images involved in this manual are for indicative purpose only. The appearance is subject to the actual equipment.
- The equipment is equipped with two power modules and two fan modules by default. The power and fan modules are fixed and cannot be removed. Both support 1+1 redundancy.

1.2 Component Modules

The M2-W6010 series adopts the modular design. Compliant with industry standards, the design differentiates modules and integrates module interfaces to ensure an integrated system with independent function modules.

Table 1-2 Component Modules

Chassis	Product ID	Airflow Direction
M2-W6010-48GT4X-FA	M2-W6010-48GT4X-FA	Front-to-rear airflow
M2-W6010-48GT4X-RA	M2-W6010-48GT4X-RA	Rear-to-front airflow

1.3 Chassis

The M2-W6010 series hardware system consists of a chassis, a power supply system, and a cooling system.

- Power supply system: provides two open frame power module slots and supports 1+1 power redundancy.
- Cooling system: provides two fan module slots and supports 1+1 fan redundancy.

1.3.1 Appearance

1. Appearance

Figure 1-1 Front View of the M2-W6010-48GT4X-FA

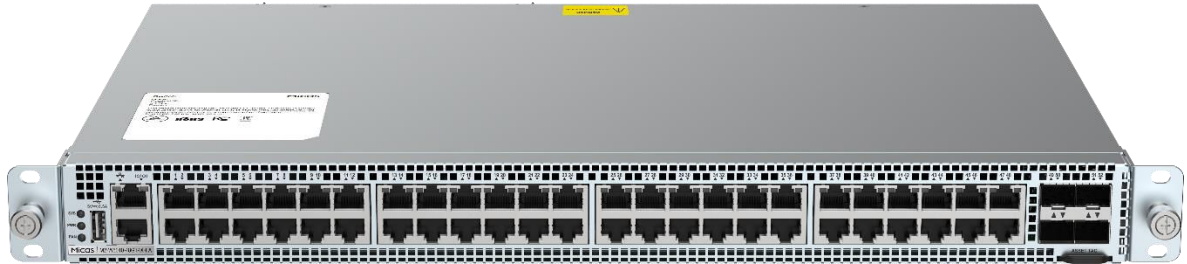

Figure 1-2 Rear View of the M2-W6010-48GT4X-FA



Figure 1-3 Front View of the M2-W6010-48GT4X-RA



Figure 1-4 Rear View of the M2-W6010-48GT4X-RA



2. Structure

Figure 1-5 Front Panel Structure

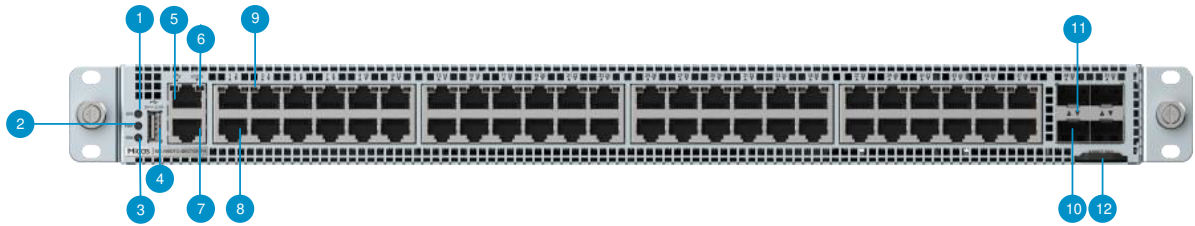

Table 1-3 Front Panel Components

No.	Component
1	SYS LED
2	Power LED
3	Fan LED
4	USB port
5	Management port
6	Management port LED
7	Console port
8	1000BASE-T port
9	1000BASE-T port LED
10	10GE SFP+ port
11	10GE SFP+ port LED
12	Asset tag

Figure 1-6 Rear Panel Structure

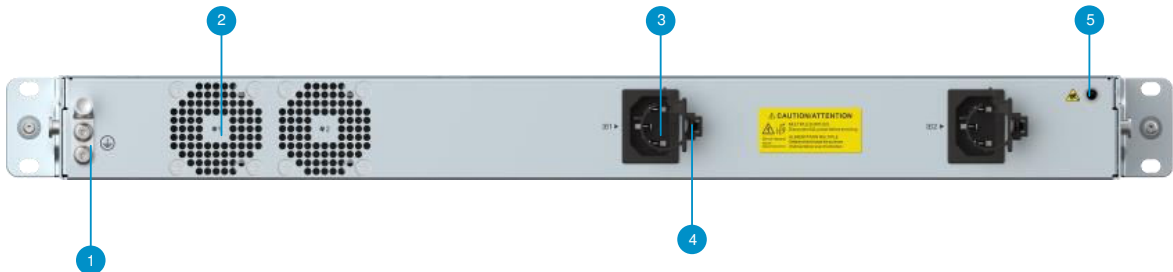

Table 1-4 Rear Panel Components

No.	Component
1	Grounding stud

No.	Component
2	Air exhaust vent
3	Power connector
4	Power cord tie
5	ESD port

1.3.2 LEDs

Table 1-5 LEDs

Silkscreen Label	LED	Description
SYS	Status LED	<ul style="list-style-type: none"> ● Solid green: The system is operating normally. ● Blinking green (3 Hz): The system is starting up. Continuous blinking indicates an anomaly. ● Blinking green (10 Hz): The LED is used for device locating. ● Solid red: The system (including all modules) is not functioning properly. ● Solid yellow: The temperature exceeds the limit or the power consumption is not enough. ● Off: The system is not receiving power or not operating even after receiving power.
PWR	Power LED	<ul style="list-style-type: none"> ● Solid green: All power modules are operating normally. ● Solid yellow: The power module model can be read but cannot be identified. ● Solid red: The redundant power module is not functioning properly or not connected with the AC power cord. ● Off: All power modules are not installed or not functioning properly after being installed.
FAN	Fan LED	<ul style="list-style-type: none"> ● Solid green: All fan modules are operating normally. ● Solid yellow: One fan module is not functioning properly, which does not affect heat dissipation. ● Solid red: At least two fan modules are not functioning properly, which affects heat dissipation. ● Off: All fan modules are not connected or not functioning properly after being connected.

Silkscreen Label	LED	Description
1 to 48	1000BASE-T port LED	<ul style="list-style-type: none"> ● Solid yellow: The port has made a successful 10/100 Mbps link. ● Blinking yellow: The port is sending and receiving traffic at 10/100 Mbps. ● Solid green: The port has made a successful 1,000 Mbps link. ● Blinking green: The port is sending and receiving traffic at 1,000 Mbps. ● Off: No link is detected for the port.
49 to 52	SFP+ port LED	<ul style="list-style-type: none"> ● Solid green: The port has made a successful 1/10 Gbps link. ● Blinking green: The port is sending and receiving traffic at 1/10 Gbps. ● Off: No link is detected for the port.
-	Management port LED	<ul style="list-style-type: none"> ● Solid yellow: The port has made a successful 10/100 Mbps link. ● Blinking yellow: The port is sending and receiving traffic at 10/100 Mbps. ● Solid green: The port has made a successful 1,000 Mbps link. ● Blinking green: The port is sending and receiving traffic at 1,000 Mbps. ● Off: No link is detected for the port.

1.3.3 Ports

Table 1-6 Ports

Port	Connector Type	Description	Accessory
1000BASE-T port	RJ45	<p>The 1000BASE-T port is backward compatible with 100BASE-T and 10BASE-T for downlink data transmission.</p> <ul style="list-style-type: none"> ● Standards compliance: IEEE802.3ab ● Working mode: Full-duplex 	CAT5 or higher cable
10GE SFP+ port	Subject to the optical module	The 10GE SFP+ port is aligned to IEEE 10GBASE-R optical specifications and backward compatible with 1000BASE-X	10GE optical module 1GE optical

Port	Connector Type	Description	Accessory
		<p>for uplink data transmission.</p> <ul style="list-style-type: none"> ● Standards compliance: IEEE802.3ae ● Working mode: Full-duplex ● Optical attributes: Subject to the module or cable 	<p>module AOC</p>
Management port	RJ45	<p>The management port is used to set up the local or remote configuration environment.</p> <ul style="list-style-type: none"> ● Standards compliance: IEEE802.3ab ● Working mode: 10/100/1000 Mbps with auto-negotiation and full-duplex 	CAT5 or higher cable
USB port	USB	<p>The USB port is connected with a USB flash drive for configuration backup and firmware upgrade.</p> <ul style="list-style-type: none"> ● USB 2.0 ● FAT32 file format 	USB 2.0 flash drive
Console port	RJ45	<p>The console port is connected to a console for local configuration.</p> <ul style="list-style-type: none"> ● Standards compliance: RS-232 ● Working mode: Duplex Universal Asynchronous Receiver/Transmitter (UART) ● Baud rate: <ul style="list-style-type: none"> ○ Range: 9,600 bits/s to 115,200 bits/s ○ Default value: 115,200 bits/s 	Console cable

1.3.4 Cooling

1. Overview

The M2-W6010 series switches adopt the front-to-rear and rear-to-front airflow:

- Front-to-rear airflow (M2-W6010-48GT4X-FA): Air flows in through the ports and out through the power module, as shown in [Figure 1-7](#).
- Rear-to-front airflow (M2-W6010-48GT4X-RA): Air flows in through the power module and out through the ports, as shown in [Figure 1-8](#).

⚠ Caution

- Maintain a minimum clearance of 200 mm (7.87 in.) around the equipment for air circulation.
 - Dust the equipment every three months to avoid blocking the ventilation openings on the housing.
-

2. Airflow

Figure 1-7 Front-to-Rear Airflow

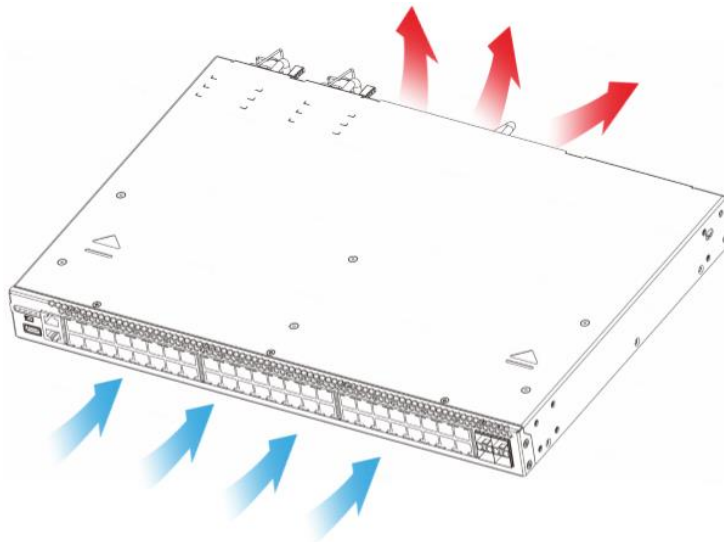
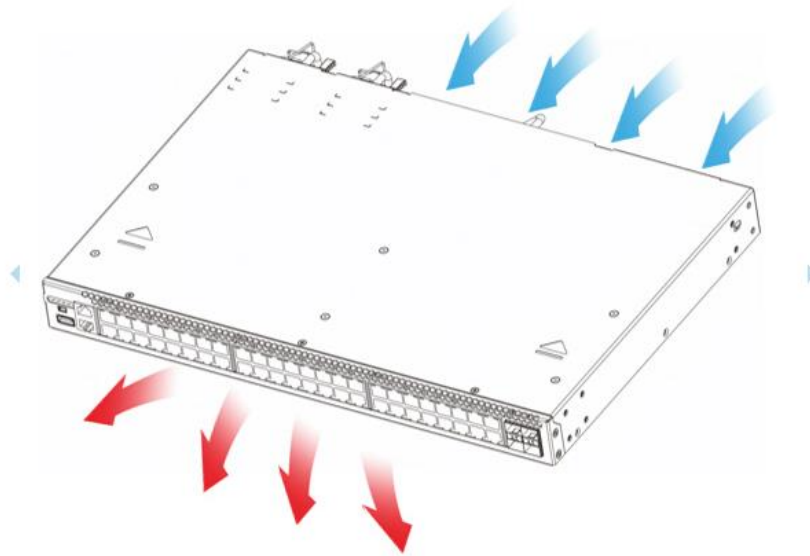

Figure 1-8 Rear-to-Front Airflow



1.3.5 Technical Specifications

Table 1-7 Technical Specifications

Class	Item	Specification
Technical indicators	CPU	1.6 GHz dual-core
	Memory	4 GB, SDRAM
	Flash memory	NOR flash: 8 MB (for BootROM)
	SSD	64 GB
Physical characteristics	Dimensions (W x D x H)	Without packing materials: 440 mm x 300 mm x 43.1 mm (17.32 in. x 11.81 in. x 1.70 in., 1 RU)
	Net weight	<ul style="list-style-type: none"> ● Chassis and modules (two fixed fan modules and two open frame power modules) without packing materials: 4.2 kg (9.26 lbs.) ● Chassis and modules with packing materials: 8.72 kg (19.22 lbs.)
	Structure	Integrated chassis without expansion module slots <ul style="list-style-type: none"> ● Two open frame power modules ● Two fixed fan modules
Ports	Downlink port	48 x 1GE, backward compatible with 100BASE-T and 10BASE-T (1000BASE-T)
	Uplink port	4 x 10GE SFP + ports, aligned to IEEE 10GBASE-R optical specifications, backward compatible with

Class	Item	Specification
		1000BASE-X
	Console port	1 x RJ45 port
	USB port	1 x UBS 2.0 port
	Management port	1 x Gigabit RJ45 port supporting backward compatibility
Environment	Altitude	<ul style="list-style-type: none"> ● Operating altitude: 0–5,000 m (0–16,404.20 ft.) ● Storage altitude: 0–5,000 m (0–16,404.20 ft.)
	Temperature	<ul style="list-style-type: none"> ● Operating temperature: 0°C to 45°C (32°F to 113°F) at an altitude in the range of 0–1,800 m (0–5,905.51 ft.) <hr/> <p>Note At an altitude in the range of 1,800–5,000 m (6,561.68–16,404.20 ft.), every time the altitude increases by 220 m (721.78 ft.), the maximum temperature decreases by 1°C (1.8°F).</p> <hr/> <ul style="list-style-type: none"> ● Storage temperature: –40°C to +70°C (–40°F to +158°F)
	Humidity	<ul style="list-style-type: none"> ● Operating humidity: 10% RH to 90% RH (non-condensing) ● Storage humidity: 5% RH to 95% RH (non-condensing)
	Noise	Sound pressure level at 27°C (80.6°F): < 78 dB
	Surge protection	AC power protection <ul style="list-style-type: none"> ● Common mode: 2 kV ● Differential mode: 1 kV
Power supply	Power supply mode	AC
	Power connector	C14 Three-pin connector
	Power consumption	<ul style="list-style-type: none"> ● Max: 70 W ● Typical: 61.6 W
	Voltage	AC: 100 V AC to 240 V AC, 50 Hz/60 Hz
	AC input	Fixed open frame power module: <ul style="list-style-type: none"> ● Rated voltage: 110 V AC/220 V AC ● Rated voltage range: 100 V AC to 240 V AC (50

Class	Item	Specification
		Hz to 60 Hz) <ul style="list-style-type: none"> ● Max. voltage range: 90 V AC to 264 V AC (47 Hz to 63 Hz) ● Max. current: 2 A
	Max. output power consumption	Fixed open frame power module: 70 W
	Airflow direction	<ul style="list-style-type: none"> ● Front-to-rear airflow (Air intake on the port side) ● Rear-to-front airflow (Air exhaust on the port side)
Cooling	Cooling mode	Drawing or blowing air
	Fan type	Fixed fan
Reliability	Mean Time to Recovery (MTTR)	0.5 hours
	Power redundancy	1+1
	Fan redundancy	1+1
	Hot swapping	Not supported
Certification	EMC standard	<ul style="list-style-type: none"> ● FCC CFR Title 47, Part 15, Subpart B ● ICES-003 Issue 7 ● ANSI C63.4
	Safety standard	<ul style="list-style-type: none"> ● EN 62368-1 ● EN BS 62368-1 ● IEC 62368-1
	Environment protection	Environment protection regulation

⚠ Warning

- Operation of this equipment in a residential environment could cause radio interference.
- This equipment is not suitable for use in locations where children are likely to be present.
- This equipment should be installed in the equipment room. Only a skilled person should be allowed to install, replace, or service this equipment. Do not open the

enclosure when the equipment is running. Cut off the power supply before opening the enclosure in case of an electric shock.

1.3.6 Asset Tag

The asset tag is in the lower right corner of the rear panel. The tag can be pulled out of the panel. You can add your own asset tracking label without interfering with the intended air flow.

Figure I-9 Asset Tag

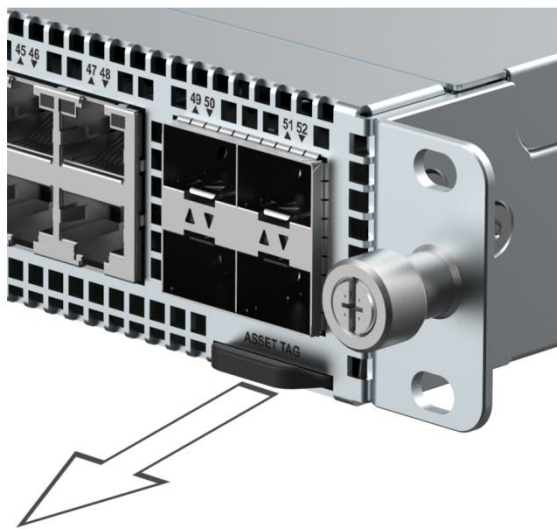

1.4 Cables

1.4.1 Ethernet Cable

- 1000BASE-T: 100-ohm CAT5e Unshielded Twisted Pair (UTP) or Shielded Twisted Pair (STP) cables with a transmission distance of up to 100 meters (328.08 ft.).
- 100BASE-TX: 100-ohm CAT5 or CAT5e UTP or STP cables with a transmission distance of up to 100 meters (328.08 ft.).
- 10BASE-T: 100-ohm CAT3, CAT4, CAT5, and CAT5e UTP or STP cables with a transmission distance of up to 100 meters (328.08 ft.).

Note

- For twisted pair connection and pin assignments, see [7.2 Connectors and Media](#).
 - The equipment supports automatic MDI/MID-X crossover detection. Both straight through and crossover cables are applicable.
-

1.4.2 Power Cord

1. Applicable Power Cords

Table 1-8 Power Cords

Chassis	Product ID	AC Power Cord
M2-W6010-48GT4X-FA	M2-W6010-48GT4X -FA	CAB-2M-IEC-10A-B(US)
M2-W6010-48GT4X-RA	M2-W6010-48GT4X -RA	CAB-2M-IEC-10A-B(US)

⚠ Caution

- The power cords that come with the power modules comply with standards of the destination country or region.
- Power cords applicable to power modules are subject to update without prior notification.

2. AC Power Cord

Select AC power cords based on the types of power sockets used in your equipment room. Micas provides the following types of power cords to suit different the power sockets:

- Power distribution unit (PDU) cords: C13 straight female to C14 straight male AC power cords, delivered with a PDU with C14 straight female connectors.
- Country-specific power cords: delivered in compliance with standards of the destination country or region.

Figure 1-10 AC Power Cord Structure



1.4.3 Grounding Wire

Figure 1-11 Grounding Wire Structure

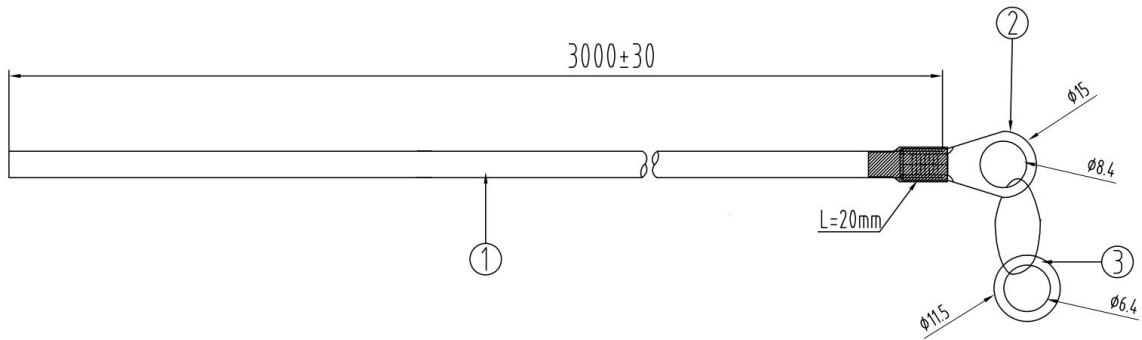

Table 1-9 Grounding Wire Components

No.	Component	Description
1	Cable sleeve	UL1015 12 AWG, yellow-green, 3 m (118.11 in.), crimping
2	Lug	HRNB 5.5-8 lug
3	Copper washer	ID: 6.4 mm (0.25 in.), OD: 11.5 mm (0.45 in.), T: 1 mm (0.04 in.)

2 Preparing for Installation

2.1 Safety Guidelines

**Note**

- To avoid personal injury or equipment damage, review the safety guidelines in this chapter before you begin the installation.
 - The following safety precautions may not include all the potentially hazardous situations.
-

2.1.1 General Precautions

- Install the equipment in a standard 19-inch EIA rack.
- Keep the chassis clear and dust free. Avoid liquid inside the equipment.
- Keep the equipment far away from heat sources.
- Ensure that the rack and power distribution system are properly grounded.
- Wear an ESD-preventive wrist strap and an ESD-preventive glove during installation and maintenance.
- Avoid disconnecting or connecting the power cord before powering off the switch.
- Keep the equipment away from walk areas.
- Do not wear loose clothing or ornament that may get caught in the chassis.
- Keep tools and components away from areas where you or others could trip over them.
- You are advised to use UPS for guaranteed power protection.
- Turn off all power supplies and unplug all power cords and cables before installing or removing the switch.

2.1.2 Chassis-Lifting Guidelines

- The chassis is not intended to be moved frequently.
- When lifting the chassis, balance the weight of the chassis between your feet.
- To prevent personal injury or equipment damage, never attempt to lift or tilt the chassis using the handles of power or fan module.
- The equipment must be installed in access-restricted locations.
- Avoid transporting the bare equipment. Instead, transport the equipment with its packing materials.
- Do not create a stack containing a greater number of chassis than what is indicated on the packing carton during transportation. Avoid placing the chassis side up or upside down.
- Do not stack bare demo units. Separate demo units using foam blocks. Do not stack over three layers, each with a height of up to 1 meter (3.28 ft.). Lay the foam blocks side-by-side.

2.1.3 Electricity Safety

- Always observe the local regulations and standards. Only trained and qualified personnel should be allowed to operate the equipment.
- Carefully check your work area for possible hazards, such as ungrounded power extension cables, missing safety grounds, and moist floors.
- Locate the emergency power-off switch in the room. In the case of an electrical accident, you will be able to quickly turn off the power.
- Never assume that power is disconnected from a circuit. Instead, always check.
- Do not subject the equipment to dampness and avoid liquid inside the equipment.

Danger

- Improper electric operations may cause a fire, electric shock, and other accidents, which may lead to severe and fatal personal injury and equipment damage.
- Direct or indirect touch through a wet object with high-voltage and mains supply can bring a fatal danger.

2.1.4 Preventing ESD Damage

Static electricity comes from two major sources:

- Outdoor high-voltage power cords, lightning, and other external electric fields
- Indoor flooring materials and equipment enclosure

When the static electricity exceeds a certain value, it will damage the circuit and equipment. To prevent ESD damage, attention should be paid to the following items:

- Ensure that the chassis is connected to earth ground.
- The site should be as dust-free as possible.
- Maintain appropriate humidity levels.
- Wear an ESD-preventive wrist strap and an ESD-preventive glove, ensuring that they are properly grounded.
- Handle component boards by their handles or edges only. Do not touch the printed circuit boards or connectors.
- Place a removed component board in a static-shielding container.
- Avoid contact between the printed circuit boards and clothing. The ESD-preventive wrist strap and glove only protect components from ESD voltages on the body. ESD voltages on clothing can still cause damage.

2.1.5 Laser Safety

The optical transceivers are Class I laser products. Attention should be paid to the following items:

- When an optical transceiver is working, ensure that the port is connected to an optical cable or covered by a dust cap to keep out dust and prevent burning your eyes.
- Do not stare into any optical port.

Danger

Do not approach or stare into any optical port under any circumstances. This may cause permanent damage to your eyes.

2.1.6 Storage Guidelines

To ensure normal operation, plan for your installation site according to the temperature and humidity requirements.

Caution

- If the equipment has been powered off for more than 18 months, power on the equipment and run it for consecutive 24 hours to activate the device.
-

2.2 Site Requirements

The equipment must be installed indoors for normal operation and prolonged service life. The following sections provide specific information to help you plan for a proper operating environment.

2.2.1 Floor Loading

Ensure that the floor under the rack supporting the chassis is capable of supporting the combined weight of the rack and all the other components.

2.2.2 Airflow

To ensure adequate airflow through the chassis, maintain a minimum clearance of 20 cm (7.87 in.) around air vents. Route the cables and power cords through the cable management brackets to avoid blocking air intake vents. Dust the equipment every three months to prevent blocking the ventilation openings on the housing.

2.2.3 Space

- You are advised to have a pathway of 0.8 meters (2.62 ft.) wide in the equipment room. This space ensures that you can remove the components and perform routing maintenance easily.
- The front and rear of the chassis must remain unobstructed to ensure adequate airflow and prevent overheating inside the chassis.

2.2.4 Temperature

To ensure normal operation and prolonged service life of the equipment, maintain an appropriate temperature in the equipment room. Otherwise, the equipment may be damaged.

- A high temperature can accelerate the aging process of insulation materials, greatly reducing the availability of the equipment and severely affecting its service life.

See [Table 1-7 Technical Specifications](#) for the temperature requirement.

Note

The operating temperature is measured at the point that is 1.5 m (4.92 ft.) above the floor and 0.4 m (1.31 ft.) before the equipment with no protective plates in front or at the back of the equipment.

2.2.5 Humidity

To ensure normal operation and prolonged service life of the equipment, maintain an appropriate humidity in the equipment room. Otherwise, the equipment may be damaged.

- In an environment with a high relative humidity, the insulating material is prone to poor insulation or even electricity leakage.
- In an environment with a low relative humidity, the insulating strip may dry and shrink, resulting in screw loosening. Furthermore, internal circuits are prone to static electricity.

See [Table 1-7 Technical Specifications](#) for the humidity requirement.

Note

The operating humidity is measured at the point that is 1.5 m (4.92 ft.) above the floor and 0.4 m (1.31 ft.) before the equipment with no protective plates in front or at the back of the equipment.

2.2.6 Cleanliness

The indoor dust takes on a positive or negative static electric charge when falling on the switch, causing poor contact of the metallic joint. Such electrostatic adhesion may occur more easily when the relative humidity is low, not only affecting the service life of the switch, but also causing communication faults. The following table lists the requirements for the dust and particles in the equipment room:

Table 2-1 Dust and Particles Requirement

Minimum Dust and Particles Diameter	Unit	Maximum Quantity
0.5 μ m	Particles/ m^3	3.5×10^5
5 μ m	Particles/ m^3	3.0×10^3

Apart from dust, there are also requirements on the salt, acid, and sulfide in the air of the equipment room. These harmful substances will accelerate metal corrosion and component aging. Therefore, the equipment room should be properly protected against harmful gases, such as sulfur dioxide and hydrogen sulfide. The following table lists limits on harmful gases.

Table 2-2 Gas Requirement

Gas	Average		Maximum (mg/m^3)	
	mg/m^3	cm^3/m^3	mg/m^3	cm^3/m^3
Sulfur dioxide (SO_2)	0.3	0.11	1.0	0.37
Hydrogen sulfide (H_2S)	0.1	0.071	0.5	0.36
Chlorine (Cl)	0.1	0.034	0.3	0.1

Gas	Average		Maximum (mg/m ³)	
	mg/m ³	cm ³ /m ³	mg/m ³	cm ³ /m ³
Nitric oxide (NO)	0.5	0.26	1.0	0.52

Note

The average value is measured over one week. The maximum value is the upper limit of the harmful gas measured in one week for up to 30 minutes every day.

2.2.7 System Grounding

A reliable grounding system is the basis for stable and reliable operation, which is indispensable for preventing lightning strikes and interference. Carefully check the grounding conditions at the installation site according to the grounding specifications, and complete grounding properly based on the site situation.

- **Safety Grounding**

Ensure that the rack and power distribution system are securely grounded. Otherwise, electric shocks may occur when the insulation resistance between the power module and the chassis becomes small.

Caution

The building should provide a protective ground connection to ensure that the equipment is connected to a protective earth.

- **Lightning Grounding**

The surge protection system is an independent system consisting of a lightning rod, a downlead conductor, and a connector connected to the grounding system. The grounding system is usually used for power reference grounding and safety grounding of the rack.

Note

See [7.3 Surge Protection](#) for details.

- **EMC Grounding**

Grounding for the EMC design includes shielded grounding, filter grounding, noise, interference suppression, and level reference.

The grounding resistance should be smaller than 1-ohm. Connect the grounding terminal to the ground before operating the equipment.

There is a grounding stud in the lower right corner of the rear panel. It is pasted with a conspicuous label.

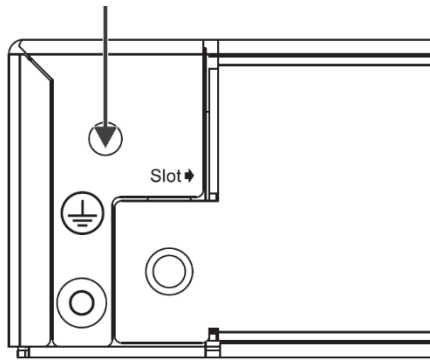
Figure 2-1 Grounding Stud

2.2.8 Preventing Electromagnetic Interference

Electromagnetic interference mainly comes from outside the equipment or application system and affects the equipment through capacitive coupling, inductive coupling, electromagnetic waves, and other conduction modes.

- Interference prevention measures should be taken for the power supply system.
- Keep the equipment far away from the grounding facility and surge protector facility of the power device.
- Keep the equipment far away from high-frequency current devices such as the high-power radio transmitting station and radar launcher.
- Take electromagnetic shielding measures when necessary.

2.2.9 Surge Protection

Although the equipment can guard against lightning strikes, strong lightning strikes may still damage the equipment. Take the following surge protection measures:

- Ensure that the grounding wire of the rack is in good close contact with the ground.
- Ensure that the neutral point of the AC power socket is in close contact with the ground.
- You are advised to install a power arrester in front of the power input end to enhance surge protection for the power supply.

2.3 Rack-Mounting Guidelines

If you plan to install the equipment on a rack, ensure that the rack meets the following requirements:

Figure 2-2 19-Inch Rack

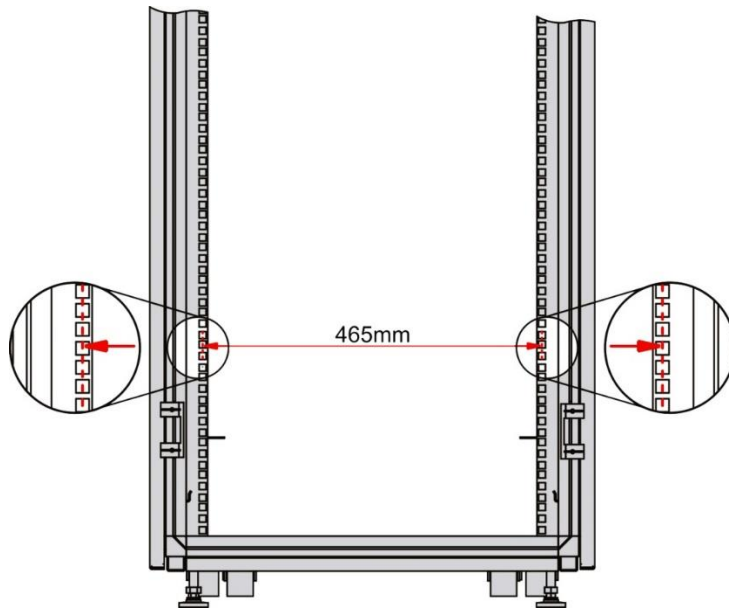

- (1) Use a four-post 19-inch EIA rack.
- (2) The left and right square hole rack posts are 465 mm (18.31 in.) apart.
- (3) The square hole rack post is at least 180 mm (7.09 in.) from the front door, and the front door is at most 25 mm (0.98 in.) thick. This ensures an available clearance of at least 155 mm (6.10 in.). The rack depth (distance between front and rear doors) is at least 1,000 mm (39.37 in.).
- (4) The guide rails or tray can bear the weight of the chassis and its components.
- (5) The rack has a reliable grounding terminal for the chassis to connect to earth ground.
- (6) The rack has a reliable heat dissipation system. The open area of front and rear doors is greater than 50%.

2.4 Tools

Table 2-3 Tools

Tools	Description
Common tools	Philips screwdriver, utility knife, adjustable wrench, ESD-preventive clothing
Dedicated tools	ESD-preventive wrist strap, ESD-preventive glove, marker, cage nuts, screws, cables, and cable ties

Note

The tool kit does not come with the equipment.

2.5 Unpacking the Switch

2.5.1 Verifying the Shipped Content

Table 2-4 Default Shipping Container Components

Kit	Description
Chassis kit	Chassis, yellow-green grounding wire, <i>Quick Start Guide</i> , <i>Package Contents</i> , and documentation
Module kit	Modules, <i>Package Contents</i> , and <i>Quick Start Guide</i>

Note

The preceding items are delivered against the purchase contract. Check your goods carefully against *Package Contents* or purchase contract. If you have any questions, contact your distributor.

2.5.2 Unpacking the Container

- (1) Cut off the packing straps on the shipping box with scissors, place the box on a flat surface, and check whether the seal on top of box is intact.

Figure 2-3

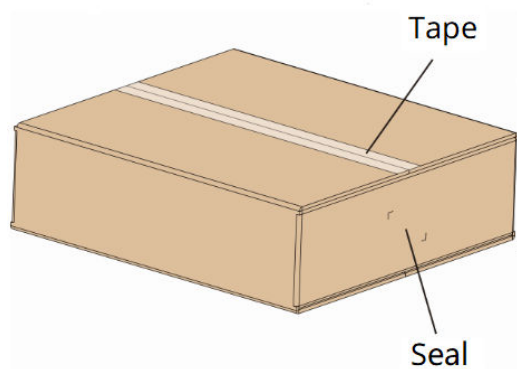

- (2) Use a paper cutter to cut the tapes holding the cardboard sleeves of the box, and open the shipping box.

Figure 2-4

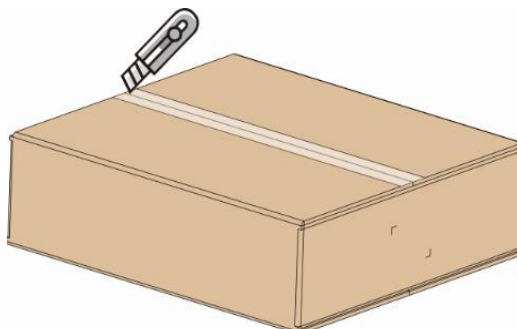

- (3) Take out the accessory box, verify that the main accessories are not missing, and then keep the accessory box handy.

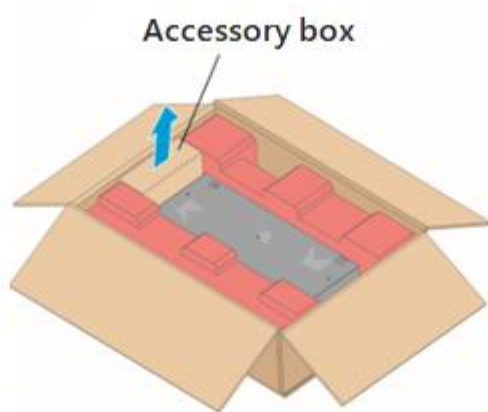
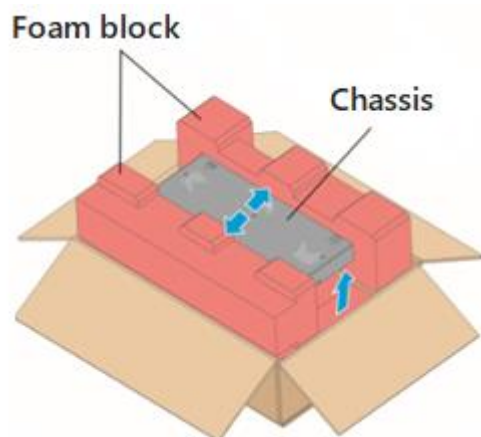
Figure 2-5**Figure 2-6**

- (4) Place the switch with the panel foam facing upwards.
- (5) Remove the panel foam and set it aside.
- (6) Move the switch with both hands onto the shipping box of another product, and remove the foam on the other side.
- (7) Remove the tape on the static-shielding container, open and reach into the bag with both hands, grab the two sides of the chassis, lift the switch out of the static-shielding container, and place it on an antistatic workbench.

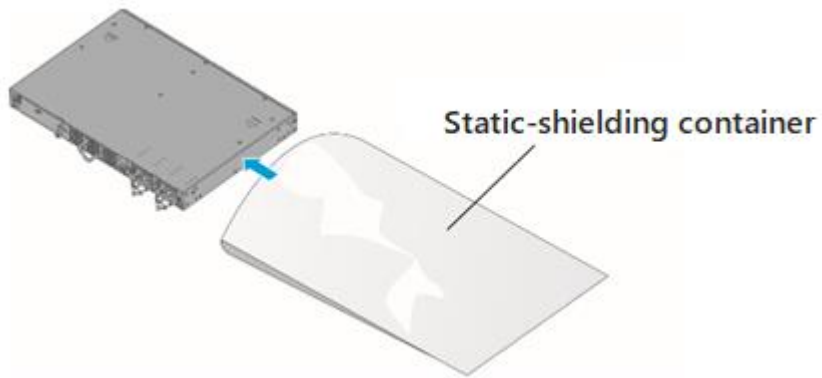
Figure 2-7

- (8) Press the power module inward to ensure that the power module is fully seated into the system.

3 Installing the Switch

Make sure that guidelines and requirements in chapter 2 have been met before you begin the installation. Plan for the installation site, networking mode, power supply, and cabling in advance.

3.1 Installation Procedure

Figure 3-1 Installation Procedure

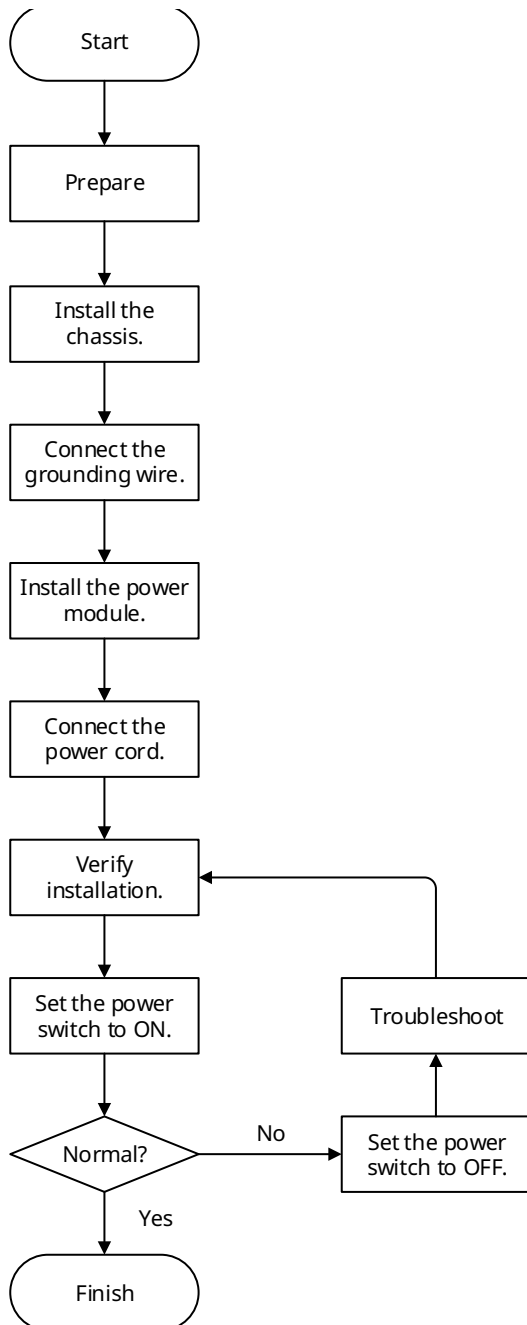

(1) [Installing the Rack](#)

- (2) [Installing the Chassis](#)
- (3) [Installing the Protective Grounding Wire](#)
- (4) [Installing and Removing the Pluggable Module](#)
- (5) [Verifying Installation](#)
- (6) [Connecting the Power Cord](#)

3.2 Installing the Rack

3.2.1 Installation Guidelines

Make sure the following guidelines are met:

- All expansion bolts for securing the rack base to the ground are installed from bottom to up in the sequence of large flat washer, spring washer, and nut, and the installation holes on the base are flush with the expansion bolts.
- The rack is stable and sturdy after installation has been completed.
- The rack is installed on the ground vertically.
- When multiple racks are placed side by side in the equipment room, they are parallel in a line with a deviation of up to 5 mm (0.20 in.).
- The front and rear doors of the rack can open and close properly after installation has been completed. Also verify that the cabinet locks are functioning and that there are a complete set of keys.
- All labeling on the rack and equipment is accurate.
- Filler panels are installed in the empty slots.
- All the screws and bolts that will be used to install the rack are of the same type.
- All modules installed in the equipment are secured and all captive screws are properly tightened.
- In order to prevent rodents and other small animals from entering the rack, the cabling exit openings at the top and bottom of the rack are fitted with rodent-resistant nets with seams of up to 15 mm (0.59 in.) in diameter.
- The rack always has a set of static-preventive wrist straps available.

Note

- See [7.4 Site Selection](#) for site selection guidelines.
 - See [7.5 Recommended Cabling](#) for cabling guidelines.
-

3.2.2 Procedure

- (1) Make sure that there is enough space before installing the rack. Reserve enough clearance before the front and rear doors for equipment maintenance.
- (2) Mount and fasten the rack in the planned location.
- (3) Install the appropriate chute and cables.
- (4) Fit the appropriate accessories to the rack.

3.3 Installing the Chassis

3.3.1 Installation Guidelines

Please verify that the front and rear brackets of the rack are in the right locations before mounting. If the front brackets are too close to the front door, there will not be sufficient clearance between the front panel and the door. As a result, the front door cannot be closed after Ethernet cables and optical fibers are connected to the chassis. Generally, maintain a minimum clearance of 10 mm (0.39 in.) between the front panel and the front door. Before installation, verify the following guidelines are met:

- The rack has been secured.
- The various components in the rack have been installed.
- There are no obstacles inside or around the rack when installing the switch.

3.3.2 Mounting the Chassis on the Rack

The chassis can be installed on a standard 19-inch EIA rack. Mount the chassis on the rack with its front panel facing forward. You are advised to use a tray or guide rails to assist in installing the chassis on the rack.

Figure 3-2 Mounting the Chassis on the Rack

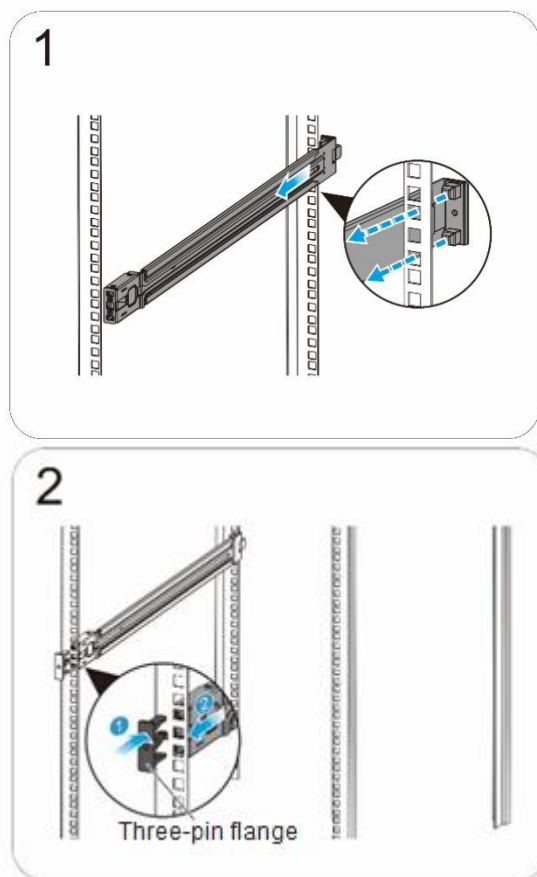

- (1) Secure the guide rail to the rear post: Position the guide rail at the desired level on the rear rack post and secure one end of the rail to the rear post using screws. Repeat with the other guide rail.

- (2) Secure the guide rail to the front post: Insert the three-pin flange through three square holes into the front rack post. Attach the other end of the guide rail to the front post by inserting the rack plug of the guide rail into the three-pin flange until the rail clip on the plug makes an audible click. Repeat with the other guide rail.

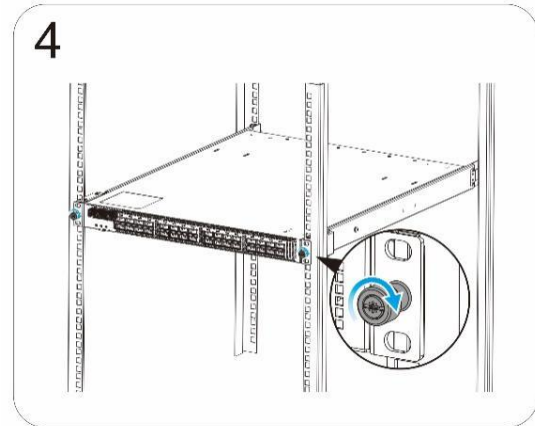
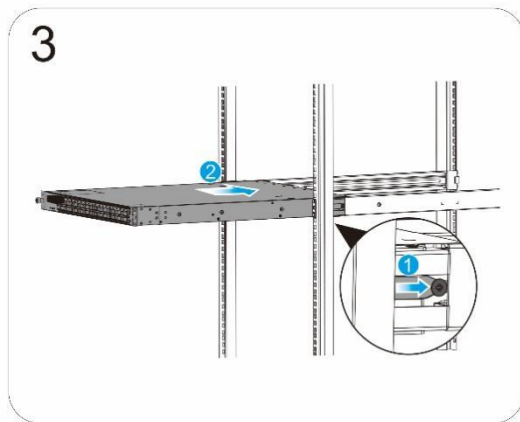

- (3) Slide the switch into the rack: Slide the rack-mount guides onto the guide rails, and then gently slide the switch all the way into the rack.
- (4) Securing the switch to the rack: Secure the switch to the rack posts using the quick-release thumb screws.

⚠ Caution

- Install the L-bracket by driving screws into the four among six screw holes on each side.
- Distinguish left and right rack-mount guide rails according to the notations.
- The rack-mount guide rails delivered with the chassis are applicable to a cabinet with a depth ranging from 800 mm (31.50 in.) to 1,200 mm (47.24 in.).

3.3.3 Mounting the Chassis on the Workbench

If a standard 19-inch EIA rack is not available, mount the switch on a clean workbench. Lay the chassis flat on the workbench and ensure adequate airflow around the chassis.

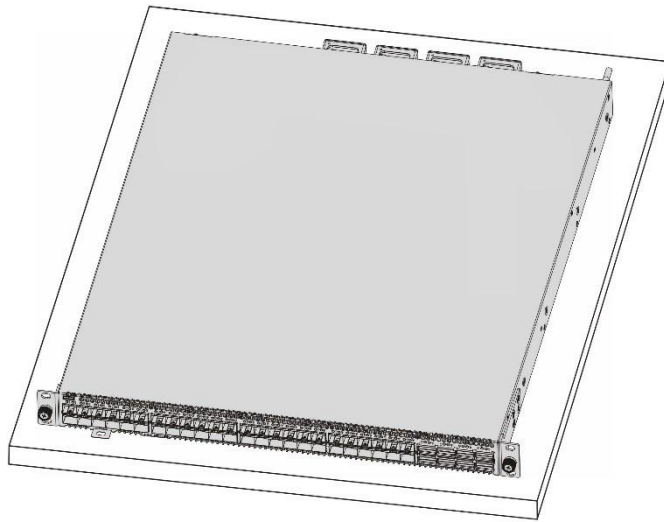
Figure 3-3 Mounting the Chassis on the Workbench

3.4 Installing the Protective Grounding Wire

3.4.1 Installation Guidelines

A reliable grounding system is the basis for stable and reliable operation, which is indispensable for preventing lightning strikes and interference. The chassis has a grounding stud on its rear panel. Connect the grounding stud to the grounding terminal of the rack and then connect the grounding terminal to the grounding bar of the equipment room.

- The cross-sectional area of the grounding wire is determined by the maximum possible current. The grounding wire should be of a good conduction quality.
- Never use bare wires.
- The combined grounding should have a grounding resistance of less than 1-ohm.

3.4.2 Procedure

- (1) Remove the grounding screw on the rear panel.
- (2) Crimp one end of the grounding wire to the grounding terminal of the chassis and the other end to the grounding terminal of the rack or the grounding bar of the equipment room.

⚡ Danger

- To ensure personal and equipment safety, it is necessary to ground the switch properly. The resistance between the chassis and the ground must be less than 0.1-ohm.
- The maintenance personnel should check whether the AC power socket is reliably connected to the building's protective ground. If not, the maintenance personnel should use a protective grounding wire to connect the protective ground terminal of the AC power socket to the building's protective ground.
- The power cord must be plugged into the power socket connected to the earth ground.

- The power socket must be installed near the equipment in an easily accessible location.
- When installing or replacing the unit, the ground connection must always be made first and disconnected last.

3.5 Installing and Removing the Pluggable Module

Note

- Make sure that you have mounted the chassis on the rack before installing the pluggable module.
 - For procedure, see *Micas Optical Module Hardware Installation and Reference Guide* for details. The documentation is subject to update without prior notification. Please access Micas Networks at <https://www.Micasnetworks.com/> for details.
-

3.6 Verifying Installation

Caution

Before verifying installation, make sure that all power supplies are turned off.

- The external power supply matches the power distribution system.
- The front and rear doors of the rack can close properly after installation has been completed.
- The rack has been completely fastened, which will not move or tilt.
- The chassis has been mounted on the rack and all cables have been fastened to the rack.
- Select the proper fan module and tighten captive screws.
- Select the proper power module.
- The power module is completely seated in the slot.
- At least two personnel are required to power on the chassis. Do not service the chassis before it is powered off.
- Carefully check your work area for possible hazards, such as ungrounded power extension cables, missing safety grounds, and moist floors.
- Do not subject the equipment to dampness and avoid liquid inside the equipment.
- Locate the emergency power-off switch in the room. In the case of an electrical accident, you will be able to quickly turn off the power.
- Never assume that power is disconnected from a circuit. Instead, always check.
- The power cord is plugged into the power module and retained there.
- The power cord is long enough to avoid over-extension.
- The power socket is connected to the earth ground as required with a rated current of at least 10 A.
- Each power module receives power from a power socket.
- If a slot is to remain empty, install a filler panel to allow for adequate airflow and to

keep dust out of the chassis.

3.7 Connecting the Power Cord

Connect the power cord according to the notation on the power module and location requirements. Take the AC power cord as an example:

- (1) Connect one end of the AC power cord to the power connector.
- (2) Connect the other end of the AC power cord to the power socket of the external power system.

 **Caution**

- Make sure the power socket is OFF before connecting the power cord.
 - Use a 3-core power cord, with a minimum cross-sectional area of 1.5 mm² or 14 AWG per pin.
 - Use a 10 A power cord for the AC power supply. Adopt the proper power socket and make sure that the AC power system in the equipment room is capable enough.
-

4 Commissioning

4.1 Setting Up the Configuration Environment

Connect the serial port of a PC to the console port of the device with a cable, as shown in [Figure 4-1](#).

Figure 4-1 Configuration Environment

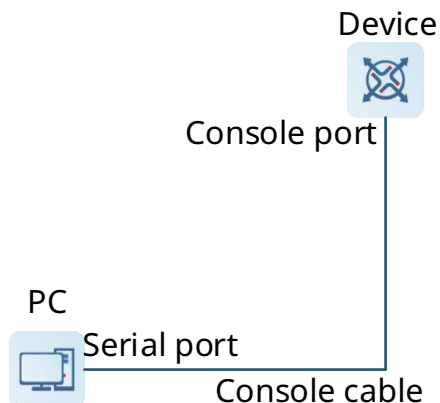

The first login to the device must be performed through the console port.

- (1) Connect the serial port of a PC to the console port of the device with a standard RS-232 cable.
- (2) Set up a local configuration environment through the console port on the front panel.
- (3) Configure communication parameters of the terminal. Run a terminal emulation software such as PuTTY:
 - a Launch PuTTY to enter its main interface.

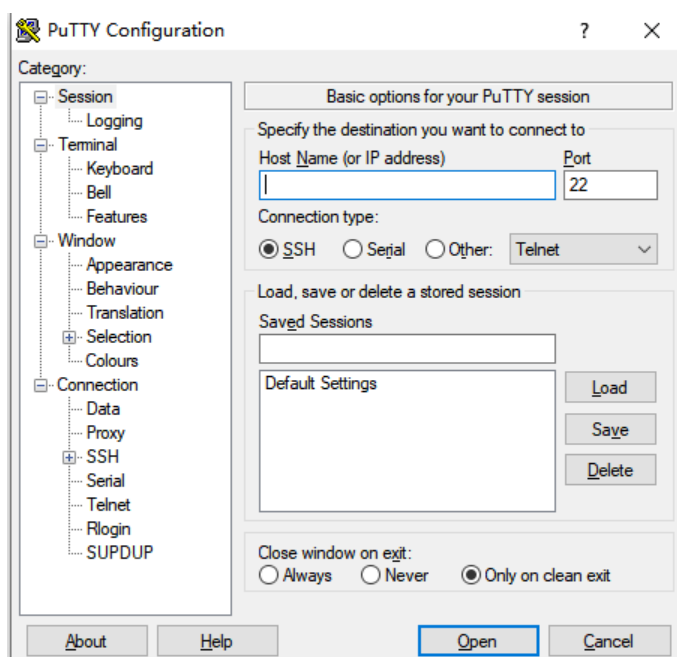

- b** Click **Serial** in the left column. Set **Bits per second** to **115,200**, **Data bits** to **8**, **Parity** to **None**, **Stop bits** to **1**, and **Flow control** to **None**.

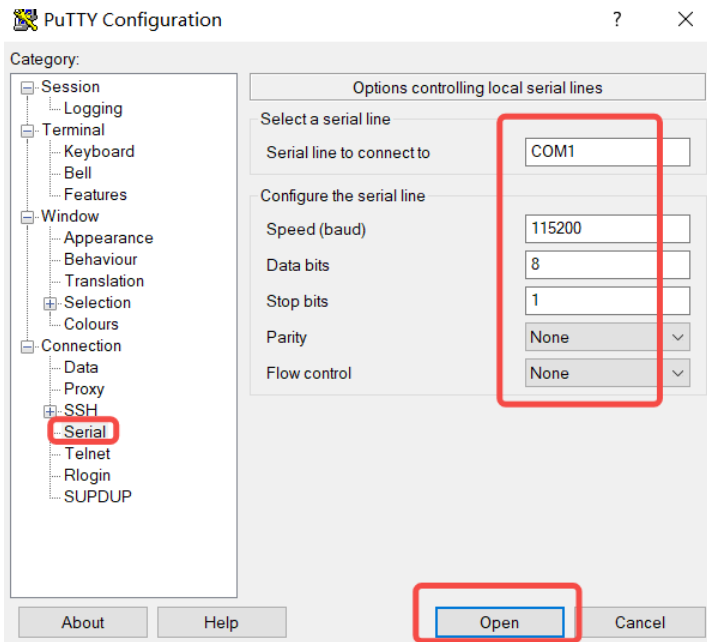

- c** Click **Open** to set up the connection.



- (4) After setting up the configuration environment, power on the device. If the device is already configured with a password, a notification will appear. Click **Accept**, and enter your username and password for connection.

4.2 Powering on the Device

4.2.1 Checklist Before Power-on

- The switch is connected to earth ground.
- The fan and power modules are properly installed.
- The power cord matching the power module is connected properly.
- The input voltage follows the requirement.

- Check whether the cable is properly connected, whether the terminal such as a PC is started, and whether terminal parameters are configured.

4.2.2 Power-on

Turn off the circuit breaker at the power supply end and set the power switch of the chassis to ON.

4.2.3 Checklist Before Power-on

- The cooling system operates normally.
- There is information output on the terminal interface.
- The LED status is normal.

5 Monitoring and Maintenance

5.1 Monitoring

5.1.1 Monitoring the LEDs

Each module installed in the chassis features a LED, which can be used to monitor the status of each module while the switch is running. See [1 Overview](#) for details.

Table 5-1 Faults Indicated by LEDs

LED Status	Fault Symptom	Suggested Action
The SYS status LED is red.	The system is not functioning properly.	Log in to the management software for troubleshooting. Cut off the power supply if necessary.
The SYS status LED is yellow.	The system is functioning but with a temperature anomaly.	
The fan status LED is off or red.	The system is functioning but with a fan anomaly.	
The power status LED is off or red.	The power module is not functioning properly.	
The system or other module status LED is red.	Other exception occurs.	

5.1.2 Running the CLI Commands

You can run CLI commands to monitor the following status:

- Whether the chassis is operating normally and whether all modules are properly installed
- Port configuration and status
- Fan and power module status
- System temperature

Note

- See *Command Reference* for monitoring commands.
 - You can log in to the device through Telnet or SSH for maintenance by running CLI commands.
-

5.2 Maintenance

5.2.1 Replacing the Lithium Battery

The equipment has a built-in lithium battery to maintain the real-time clock without external power supply.

To replace the lithium battery, please contact your distributor or technical support team.

Danger

- There is the danger of explosion if the battery is replaced incorrectly. Replace the battery only with the same or equivalent type recommended by the manufacturer.
- Dispose the replaced lithium battery properly. Subjecting the battery to extremely high temperatures, extremely low air pressure, fire, or microwave oven may cause flammable liquid or gas leakage or even the danger of explosion.

5.2.2 Replacing the Fuse

To replace the fuse, please contact your distributor or technical support team.

Table 5-2 Fuse Specifications

Chassis	Product ID	Fuse Bits	Specifications
M2-W6010-48GT4X-FA	M2-W6010-48GT4X-FA	F1	F 5 A/125 V
M2-W6010-48GT4X-RA	M2-W6010-48GT4X-RA	F1	F 5 A/125 V

6 Troubleshooting

6.1 Flowchart

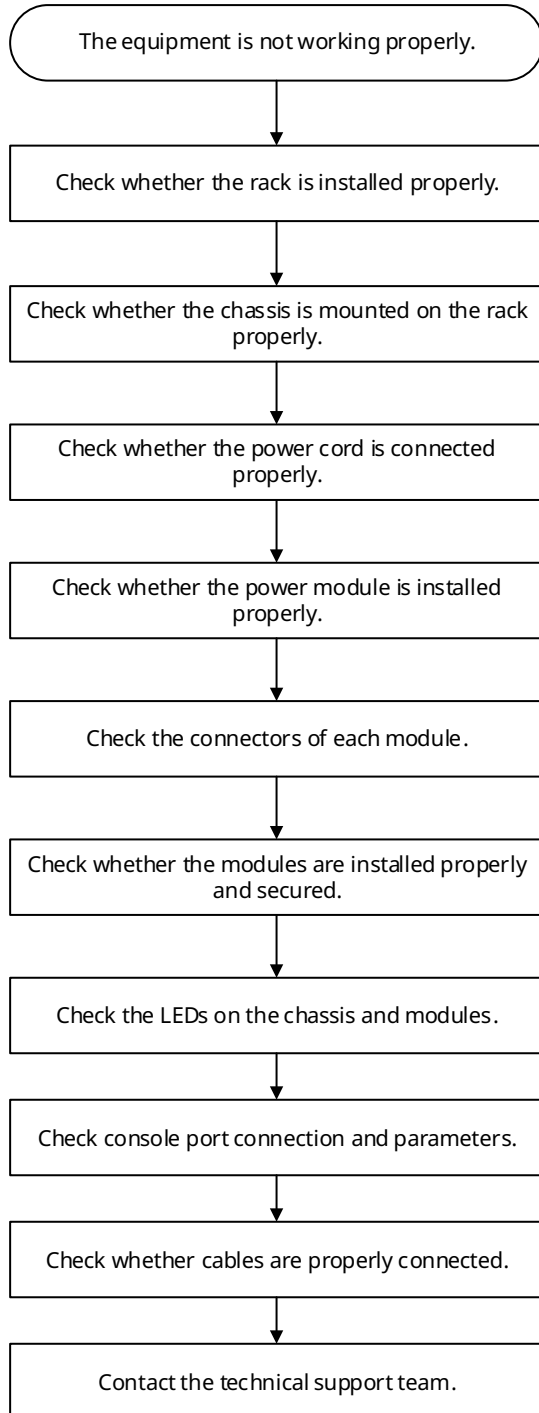

6.2 Common Issues

6.2.1 Forgetting Login Password

Symptom

The login password is forgotten.

Handling Method

Contact Micas technical support team.

6.2.2 AC Power Module Failure

Symptom

All LEDs on the front panel are off. The fan status LED is off, and the fan does not rotate.

Handling Method

- (1) Unplug the power cord from the power module.
- (2) Check whether the power cord is securely connected to the power socket.
- (3) Check whether the power cord is securely connected to the power module.
- (4) Check whether the power module is securely seated. If necessary, pull out the power module and check its connector.
- (5) Check whether the power cord matches the power supply.

6.2.3 Fan Module Not Rotating

Symptom

After the system is powered on, the fan does not rotate or the fan status LED is not on.

Handling Method

Check whether the fan module plugs into the receptacle at the back of the slot. If yes, please replace the fan module.

6.2.4 No Output on the Console

Symptom

After the system starts, there is no output on the console.

Handling Method

Check whether the console cable is properly connected. Ensure that the connected serial port is consistent with what is configured on the HyperTerminal and that the configuration of the serial port on the HyperTerminal is consistent with that in *Configuration Guide*. If there is still no console output, contact Micas technical support team.

6.2.5 Garbled Output on the Console

Symptom

The console output is garbled.

Handling Method

The fault is related to the serial port configuration. Check whether baud rate configuration is consistent with that in *Configuration Guide*.

6.2.6 Optical Port Linkdown

Symptom

The system runs normally. After you insert an optical transceiver into an optical port and plug in an optical cable, the link cannot be set up.

Handling Method

- a** Check whether the receive and transmit ends are reversed. The transmit end of an optical port must be connected to the receive end of the peer port. You can confirm both ends by exchanging the connection order of two optical cables.
- b** Check whether wavelengths of optical transceivers on both sides are consistent. For example, an optical transceiver with a wavelength of 1310 nm cannot be connected to an optical transceiver of 1550 nm.
- c** Check whether the distance between two sides exceeds the maximum length marked on the optical transceiver.
- d** Check whether the speeds of two sides are consistent and whether the optical cable type meets requirements. For ports supporting different speeds, check their speed settings.

7 Appendix

7.1 Labeling Process

7.1.1 Hand Writing on Labels

Writing tool: black gel pen

7.1.2 Pasting Labels

Fill in the label content on the full-page label paper before attaching the label, and then paste it on the power cord or signboard wire buckle.

(1) Label pasting position

Paste the label 2 cm (0.79 in.) away from the plug. In some specific situations, avoid cable bending or the position that affects power cord installation. The label is pasted on the power cord with the long text area always facing right or downwards, as shown in [Figure 7-1](#). The flowchart is described as follows:

- a** At the label attachment, keep the label facing right when the power cable is laid vertically.
- b** Keep the label facing downwards when the power cord is laid horizontally.

Figure 7-1 Keeping the Label Text Area Facing Right or Downwards

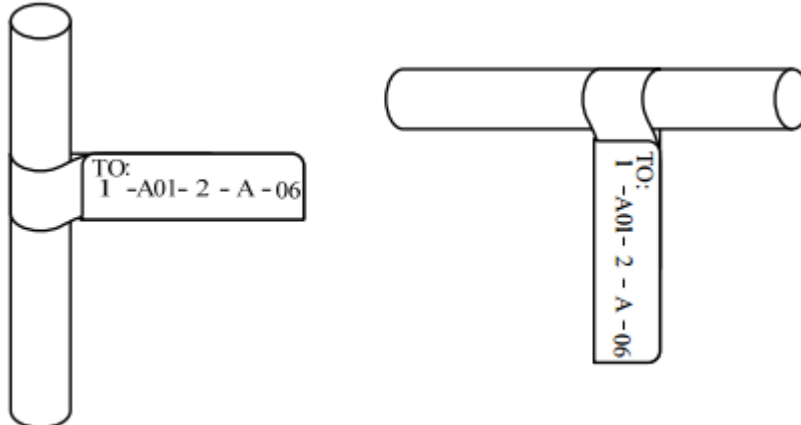

(2) Labeling procedure

Figure 7-2 Signal Cable Labeling Procedure

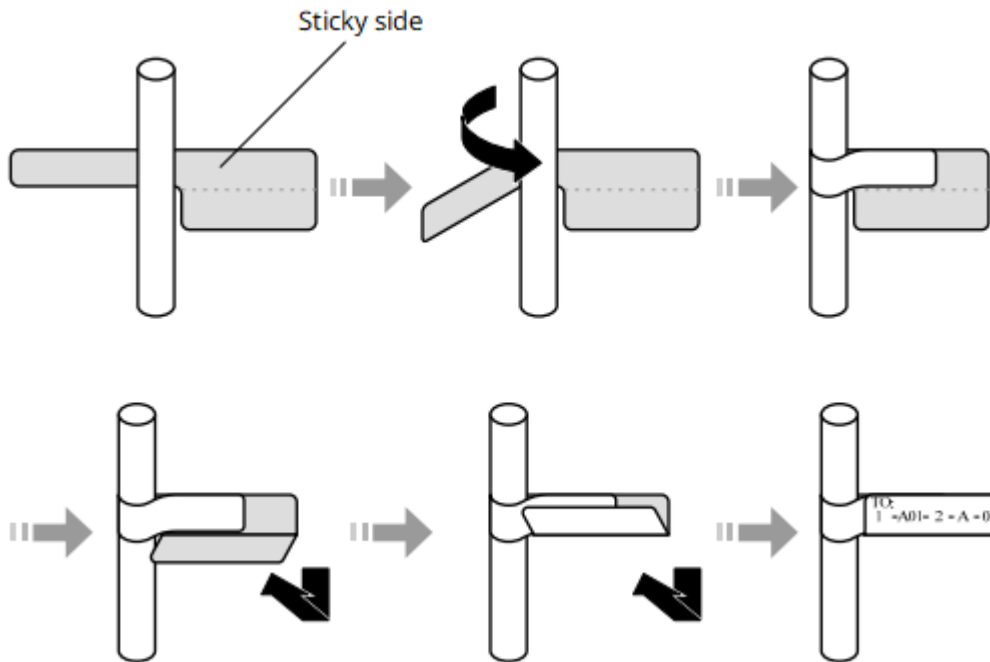

7.1.3 Label Contents

The contents of the two sides of the label identify the location of the ports connected to the two ends of the power cord. Fill in the label according to the specific environment.

- (1) Fill the content of the local end of the cord location in area ①.
- (2) Fill the content of the remote end of the cord location in area ②.
- (3) Area ③ is collapsed when the label is pasted.

Figure 7-3 Signal Cable Label

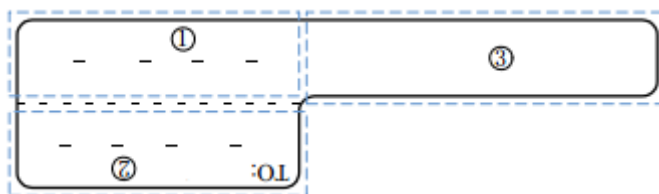

7.2 Connectors and Media

7.2.1 1000BASE-T Port

Compliant with the IEEE 802.3ab standard, 1000BASE-T requires CAT5, CAT5e or higher standard 100-ohm twisted pairs with a distance of up to 100 meters (328.08 ft.). The 1000BASE-T port employs four pairs of wires for data transmission. [Figure 7-4](#) shows the twisted pair connection for the 1000BASE-T port. The connection method and signal description are provided considering self-made cables. Keep the side without the RJ45 locking clip facing yourself. The signal cables are numbered 1 to 8 from left to right.

Figure 7-4 Cable Connection Modes and Signals

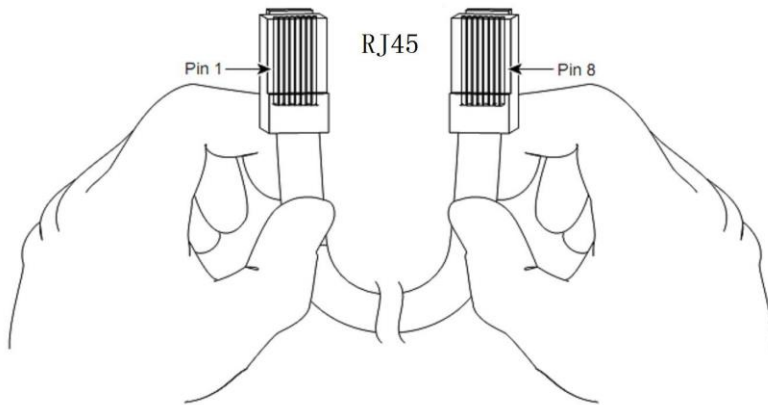
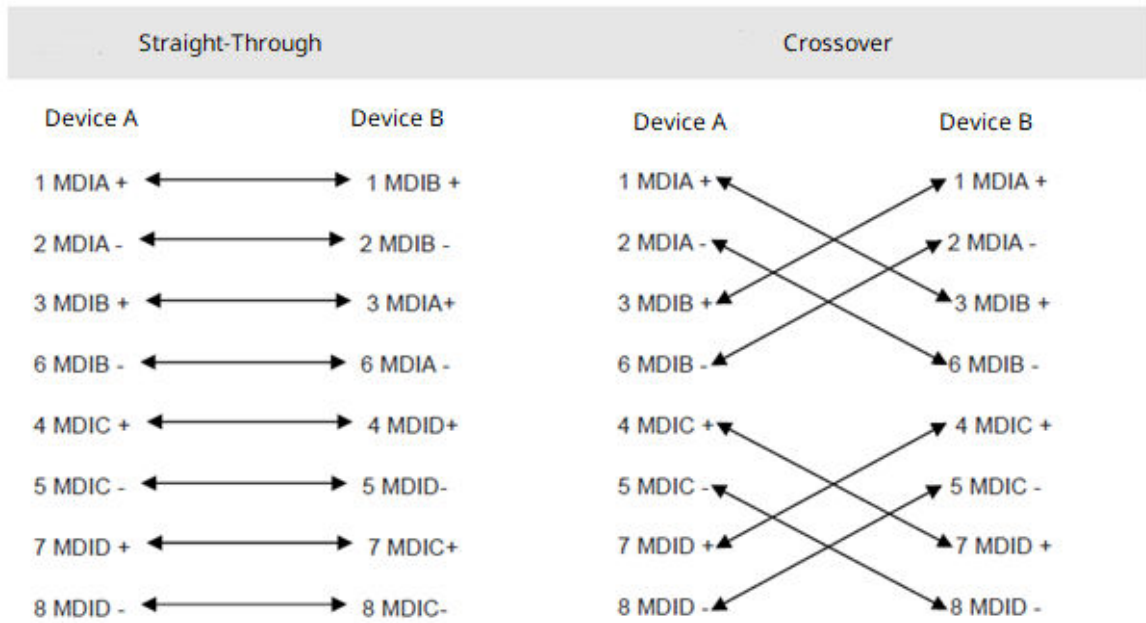

Table 7-1 1000BASE-T Pin Assignment

Pin	MDI Mode	MDI-X Mode
1	Media Dependent Interface A+	Media Dependent Interface B+
2	Media Dependent Interface A-	Media Dependent Interface B-
3	Media Dependent Interface B+	Media Dependent Interface A+
4	Media Dependent Interface C+	Media Dependent Interface D+
5	Media Dependent Interface C-	Media Dependent Interface D-
6	Media Dependent Interface B-	Media Dependent Interface A-
7	Media Dependent Interface D+	Media Dependent Interface C+
8	Media Dependent Interface D-	Media Dependent Interface C-

The 1000BASE-T port employs all four pairs of wires for data transmission. [Figure 7-5](#) shows the twisted pair connection for the 1000BASE-T port.

Figure 7-5 1000BASE-T Twisted Pair Connections



7.2.2 100BASE-TX/10BASE-T Port

Table 7-2 100BASE-TX/10BASE-T Pin Assignment

Pin	MDI Mode	MDI-X Mode
1	Output Transmit Data+	Input Receive Data+
2	Output Transmit Data-	Input Receive Data--
3	Input Receive Data+	Output Transmit Data+
6	Input Receive Data-	Output Transmit Data-
4, 5, 7, 8	Not Used	Not Used

The following figure shows 100BASE-TX/10BASE-T straight-through and crossover cables.

Figure 7-6 100BASE-TX/10BASE-T Twisted Pairs

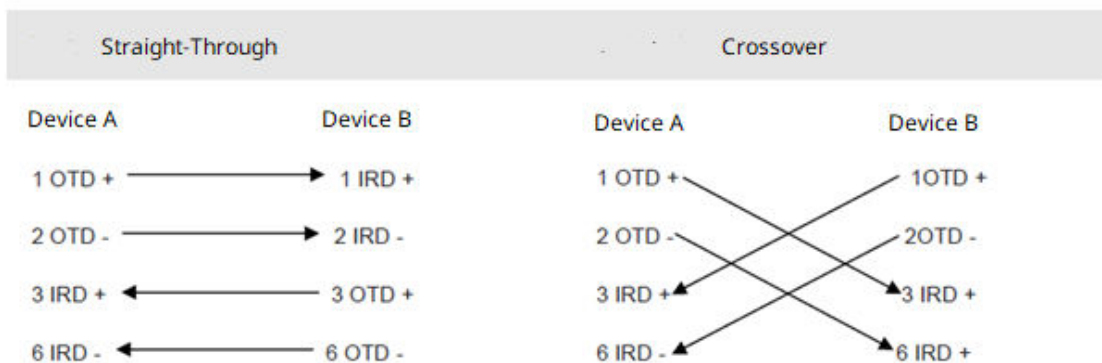

7.3 Surge Protection

7.3.1 Installing an AC Power Arrester

When an AC power cord from outdoors is directly plugged into the power port of the switch, the AC power connector must be connected to an external surge protector power strip to protect the switch against lightning strikes. The surge protector power strip can be fixed on the rack, workbench, or wall in the equipment room by using cable ties and screws. AC power enters the switch through the surge protector power strip. AC power enters the switch through the surge protector power strip.

Figure 7-7 Power Arrester

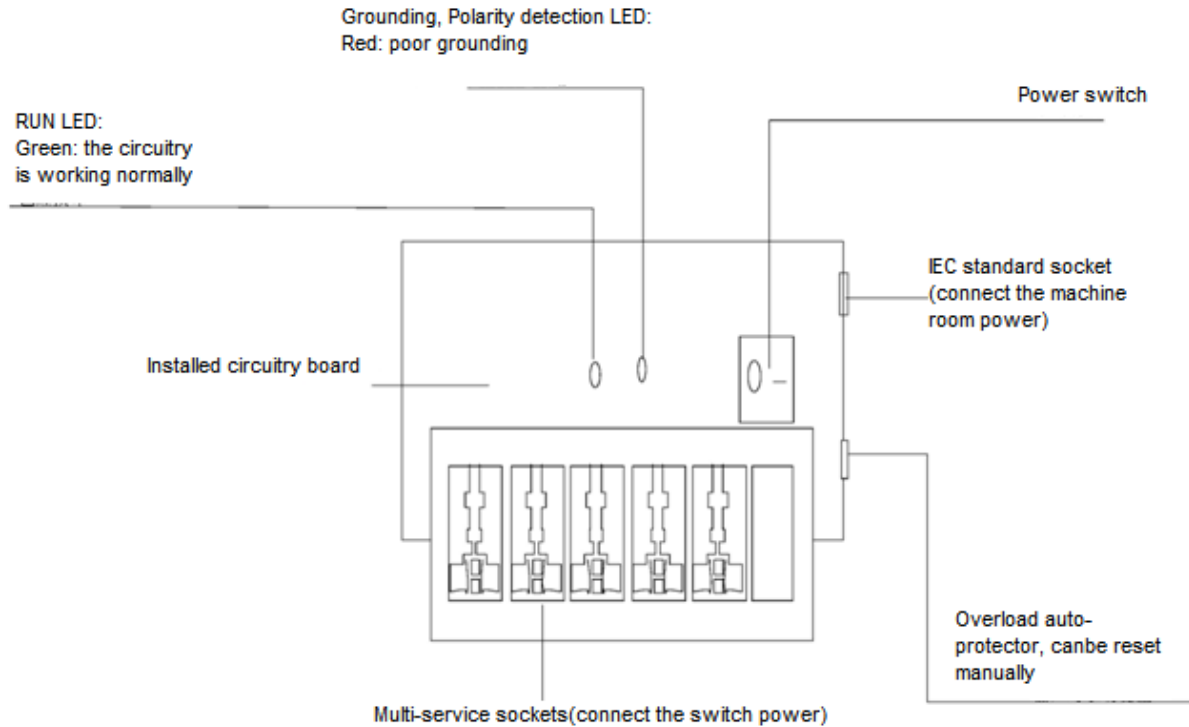

Note

The power arrester does not come with the equipment. Please purchase it based on actual requirements.

Important points:

- Make sure that the PE terminal of the power arrester is well grounded.
- After the AC power plug of the switch is connected to the socket of the power arrester (surge protector power strip), the surge protection function is implemented only if the LED indicating operation status is green and the LED indicating alarm status is OFF.
- If the LED on the power arrester turns red, check whether it is caused by poor grounding connection or by the reversed connection of the null and live lines. The detection method is as follows: Use a multimeter to measure the polarity of the power socket for the arrester when the LED turns red. If the null line is on the left and the live line is on the right (facing the socket), the arrester's PE terminal is not grounded. If not, the null and live lines are reversed. In this case, you should open the power arrester and reverse the null and live lines. If the LED is still red, the arrester's PE terminal is not

grounded.

7.3.2 Installing an Ethernet Port Arrester

Please connect an Ethernet port arrester to the switch to prevent the damage by lightning before connecting an outdoor network cable to the switch.

Tools: Phillips screwdrivers or flat-head screwdriver, multimeter, and diagonal pliers

Procedure:

- (1) Tear one side of the protective paper for the double-sided adhesive tape and paste the tape to the enclosure of the Ethernet port arrester. Tear the other side of the protective paper for the double-sided adhesive tape and paste the Ethernet port arrester to the switch enclosure. The paste position for the Ethernet port arrester should be as close to the grounding terminal of the switch as possible.
- (2) According to the distance between the switch grounding terminal and the Ethernet port arrester, trim the grounding wire for the Ethernet port arrester and firmly crimp the grounding wire to the grounding lug of the switch.
- (3) Use a multimeter to check whether the grounding wire for the arrester is in good contact with the grounding terminal and the enclosure of the switch.
- (4) Connect the arrester by using an adapter cable (note that the external network cable is connected to the IN end, while the adapter cable connected to the switch is connected to the OUT end) and check whether the service module LED is normal.
- (5) Use a nylon cable tie to bundle the power cords.

Figure 7-8 Installing an Ethernet Port Arrester

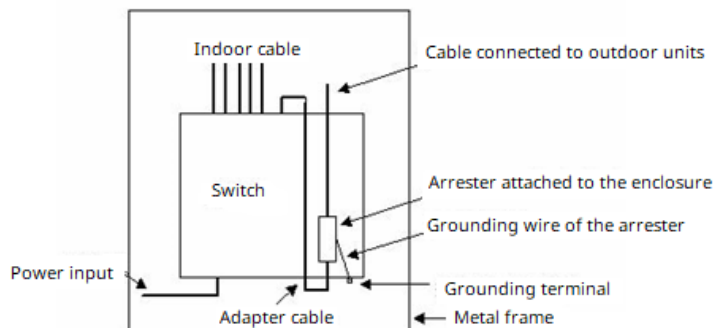

Note

- The Ethernet port arrester is only for the 10/100 Mbps electrical ports with an RJ-45 connector.
- The Ethernet port arrester is not delivered with the switch. Please purchase it as required. The Ethernet port arrester user manual contains technical parameters and maintenance and installation instructions for the Ethernet port arrester. Carefully read this manual before installation.

Caution is needed to avoid the following cases:

- Reversed installation direction of the arrester. Connect the external network cable to the **IN** end and connect the Ethernet port of the switch to the **OUT** end.
- Poor grounding of the arrester. The grounding wire of the arrester should be as short

as possible to ensure that it is in good contact with the grounding terminal of the switch. Use a multimeter to confirm the contact condition after grounding.

- Incomplete arrester installation. If there is more than one port connected to external power cords, arresters need to be installed on all connection ports for the purpose of surge protection.

7.4 Site Selection

- The equipment room should be at least 5 km (16,404.20 ft.) away from heavy pollution sources, such as the smelter works, coal mine, and thermal power plant. The equipment room should be at least 3.7 km (12,139.11 ft.) away from medium pollution sources, such as the chemical factory, rubber factory, and electroplating factory. The equipment room should be at least 2 km (6,561.68 ft.) away from light pollution sources, such as the food factory and leather plant. If the pollution source is unavoidable, the equipment room should be located on the windward side of the pollution source perennially with advanced protection.
- The equipment room should be at least 3.7 km (12,139.11 ft.) away from the sea or salt lake. Otherwise, the equipment room must be sealed, with air conditioner installed for temperature control. Saline soil cannot be used for construction. Otherwise, you should select equipment with advanced protection against severe environment.
- Do not build the equipment room in the proximity of livestock farms. Otherwise, the equipment room should be located on the windward side of the pollution source perennially. The previous livestock house or fertilizer warehouse cannot be used as the equipment room.
- The equipment room should be firm enough to withstand severe weather conditions such as windstorm and heavy rain as well as away from dust. If the dust is unavoidable, keep the door and window away from the pollution source.
- The equipment room should be away from the residential area. Otherwise, the equipment room should meet the construction standard in terms of noise.
- Make sure the air vent of the equipment room is away from the sewage pipe, septic tank, and sewage treatment tank. Keep the equipment room under positive pressure to prevent corrosive gas from entering the equipment room to corrode components and circuit boards.
- Keep the equipment room away from industrial boiler and heating boiler.
- The equipment room should be on the second floor. Otherwise, the equipment room floor should be 600 mm (23.62 in.) higher than the highest flood level ever recorded.
- Make sure there are no cracks or holes in the wall and floor. If there are cable entries in the wall or window, take proper sealing measures. Ensure that the wall is flat, wear-resistant, and dust-free, which should be up to the standard for flame retarding, soundproofing, heat absorption, dust reduction, and electromagnetic shielding.
- Keep the door and the window closed to make the equipment room sealed.
- The steel door is recommended for soundproofing.
- Sulfur-containing materials are forbidden.
- Keep the air conditioner from blowing wind straight toward the equipment or blowing water drops from the window or air vent toward the equipment.

7.5 Recommended Cabling

When the switch is installed in a standard 19-inch rack, route the cables through the cable management brackets. Top cabling or bottom cabling is adopted according to

the actual situation in the equipment room. All conversion connectors should be placed at the bottom of the rack instead of outside the rack that is easily accessible. Power cords are routed beside the rack, and top cabling or bottom cabling is adopted according to the locations of the AC power socket, surge protection box in the equipment room, or DC PDU.

- Requirements for the Minimum Bend Radius of Ethernet Cables
 - The bend radius of a fixed power cord, Ethernet cable, or flat cable should be over five times greater than their respective diameters. The bend radius of these cables that are often bent or plugged should be over seven times greater than their respective diameters.
 - The bend radius of a fixed common coaxial cable should be over seven times greater than its diameter. The bend radius of the common coaxial cable that is often bent or plugged should be over 10 times greater than its diameter.
 - The bend radius of a fixed high-speed cable (such as SFP+ cable) should be over five times greater than its diameter. The bend radius of the fixed high-speed cable that is often bent or plugged should be over 10 times greater than its diameter.
- Requirements for the Minimum Bend Radius of Optical Cables
 - The diameter of a fiber splice tray to hold fibers should be over 25 times greater than the diameter of the fiber.
 - When an optical cable is moved, the bend radius of the optical cable should be over 20 times greater than the diameter of the optical cable.
 - During cabling, the bend radius of the optical cable should be over 10 times greater than the diameter of the optical cable.
- Precautions for Bundling up Cables
 - Before cables are bundled, mark labels and paste the labels to cables.
 - Cables should be neatly and properly bundled in the rack without twisting or bending.

Figure 7-9 Bundling Up Cables (1)

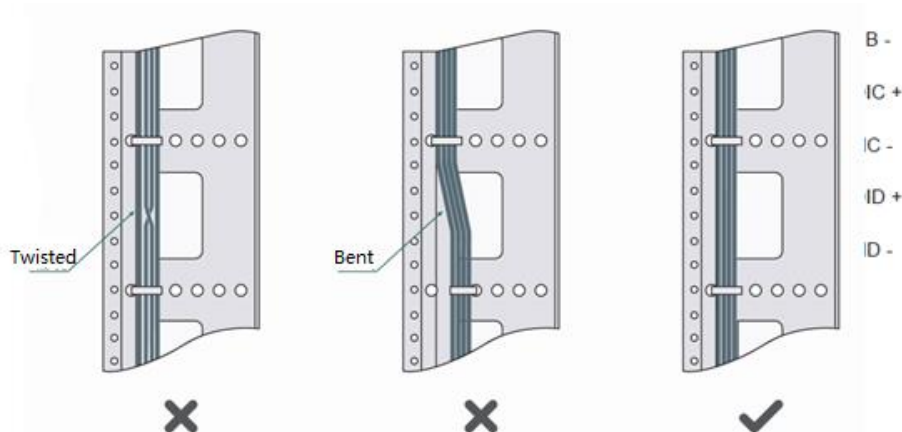

- Cables of different types (such as power cords, signal cables, and grounding wires) should be separated in cabling and bundling. Mixed bundling is not allowed. When they are close to each other, you are advised to adopt crossover cabling. In the case of parallel cabling, maintain a minimum distance of 30 mm (1.18 in.) between power cords and signal cables.

- The cable management brackets and chute inside and outside the rack should be smooth without sharp corners.
- The metal hole traversed by cables should have a smooth and fully rounding surface or an insulated lining.
- Use cable ties to bundle up cables properly. Please do not connect two or more cable ties to bundle up cables.
- After bundling up cables with cable ties, cut off the remaining part. The cut should be smooth and trim, without sharp corners, as shown in [Figure 7-10](#).

Figure 7-10 Bundling Up Cables (2)

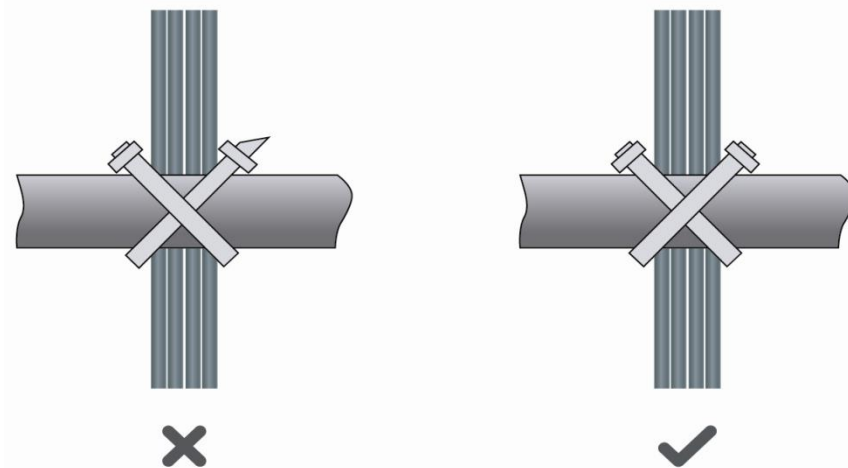

- When cables need to be bent, please bundle them up but do not tie them where the cables will be bent, as shown in [Figure 7-11](#).

Figure 7-11 Bundling Up Cables (3)

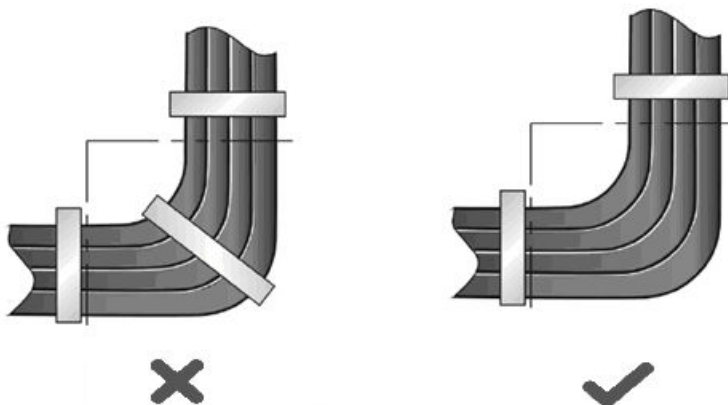

- Cables not to be assembled or remaining parts of cables should be folded and placed in a proper position of the rack or cable trough. The proper position refers to a position that does not affect switch performance or damage the switch or cable.
- 220 V and -48 V power cords must not be bundled on the guide rails of moving parts.
- Leave a margin for the power cords connecting moving parts such as door grounding wires after they are connected to avoid suffering tension or stress. When the moving part is installed, the remaining cable part should not touch heat sources or sharp corners. If heat sources cannot be avoided, high-temperature cables should be adopted.

- For the cable terminals fastened by screw threads, tighten the bolt or screw and take cable retention measures, as shown in [Figure 7-12](#).

Figure 7-12 Cable Fastening

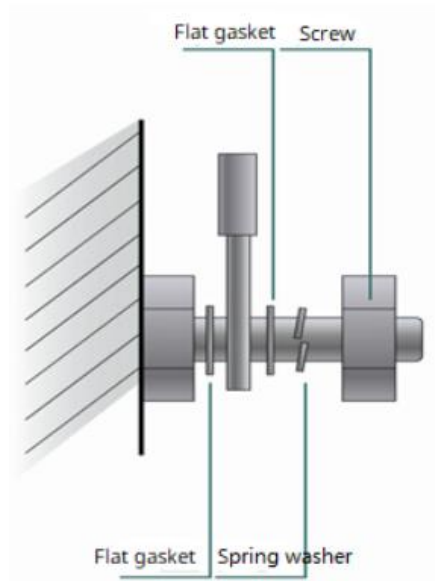

- Hard power cords should be fastened in the terminal connection area to prevent stress on terminal connection and cable.
- Do not use self-tapping screws to fasten terminals.
- Power cords of the same type and in the same cabling orientation should be bundled up into one cable bundle. The power cords in the bundle should be clean and straight.
- Bundle up cables by using cable ties.

Table 7-3 Cable Bundling

Cable Bundle Diameter	Distance between Every Binding Point
10 mm (0.39 in.)	80 mm to 150 mm (3.15 in. to 5.91 in.)
10 mm to 30 mm (0.39 in. to 1.18 in.)	150 mm to 200 mm (5.91 in. to 7.87 in.)
30 mm (1.18 in.)	200 mm to 300 mm (7.87 in. to 11.81 in.)

- No knot is allowed in cabling or bundling.
- For wiring terminal blocks (such as circuit breakers) with insulated terminals, the metal part of the insulated terminal should not be exposed outside the terminal block during assembling.